

MUELLER® GAS

Line Stopper Unit No. 3SW™

⚠ WARNING:

1. Read and follow instructions carefully. Proper training and periodic review regarding the use of this equipment is essential to prevent possible serious injury and/or property damage. The instructions contained herein were developed for using this equipment on fittings of Mueller manufacturer only, and may not be applicable for any other use.
2. DO NOT exceed the pressure ratings of any components or equipment. Exceeding the rated pressure may result in serious injury and/or property damage.
3. Safety goggles and other appropriate protective gear should be used. Failure to do so could result in serious injury.
4. Pressure test, check for and repair leaks in all fittings and components each time one is installed or any joint or connection is broken. Failure to find and repair a leak from any source in the fittings, bypass lines or equipment could result in an explosion and subsequent serious injury and/or property damage.
5. MUELLER® Drilling Machines and Equipment have been carefully designed and engineered to work together as a unit. The use of equipment manufactured by someone other than Mueller Co. may cause excessive wear or a malfunction of the Mueller machines.

TABLE OF CONTENTS PAGE

Equipment and Maintenance	2
H-17346 Completion Machine	2
Installing and Stopping-off 4", 6" and 8" Line Stopper Fittings, Flanged Tees, and Save-A-Valves	3-13
Installing Flanged Tee Stopper	14
Calculating Number of Turns to Contact Main	15
Using H-17619 Inspection Flange	15



Reliable Connections™

Customer Service Center

Decatur, Illinois

1.800.798.3131

www.muellergas.com

moreinfo@muellercompany.com

All warranties, expressed or implied, for Mueller Drilling Machines are rendered null and void if the machines are used with shell cutters or equipment manufactured by someone other than Mueller Co.

MUELLER® Line Stopper Unit No. 3SW

General Information / Maintenance

Capacity and Use

The 3SW Stopping Machine is used to stop-off 4", 6" and 8" Line Stopper Fittings and Flanged Service Tees. The body has an integral 2" F.I.P. thread bypass connection.

Line Stopper Fittings are often used in pairs to isolate a section of pipe line. For this reason Unit No. 3SW consists of machines and attachments for stopping-off two line stopper fittings at the same time. Only one set of attachments is required for drilling the pipe line, aligning the completion plug, inserting the completion plug and extracting the completion plug since these operations can be done on one fitting at a time. The H-17340 Stopping Machine includes a special 9¹/₄" gate valve, combined crank and lifting yoke and necessary bolts and gaskets.

Working Pressure and Temperature Rating

- 275 psig (1898 kPa) Maximum Working Pressure.
- 100° F (38° C) Maximum Temperature Rating

The line pressure and temperature must not exceed this amount when using this machine and equipment. If appropriate, the line pressure may be increased to maximum working pressure of fitting after completion plug and cap are securely in place.

⚠ CAUTION: The max. working pressure for the H-17265, H-17266 and H-17285 Mechanical Joint Line Stopper Fittings is 175 psi. When using the H-17265, H-17266 or H-17285 the line pressure must not exceed this amount.

Equipment

The equipment required for installing and stopping off 4", 6" and 8" Line Stopper Fittings consists of:

- One Mueller C1-36 Drilling Machine
- Two H-17340 Stopping Machines
- One H-17346 Completion Machine
- One set of Unit 3SW attachments.

H-17346 Completion Machine

The Completion Machine is used to extract or insert completion plugs, and also to align all equipment on the fitting before the drilling and/or stopping operation is started.

This machine has a balanced pressure design permitting machine shaft to be easily advanced or retracted. It is never necessary to operate machine against full effective force of line pressure.

Completion Machine Attachments

The H-17346 completion machine attachments include inserting tool, extracting tool, alignment tool, completion plug wrench, and thread cleaning tool for 6" and 8". (4" tools sold separately).

For complete information on the uses of these machines and the equipment and attachments required for their use see the latest Mueller Gas Catalog at muellergas.com.

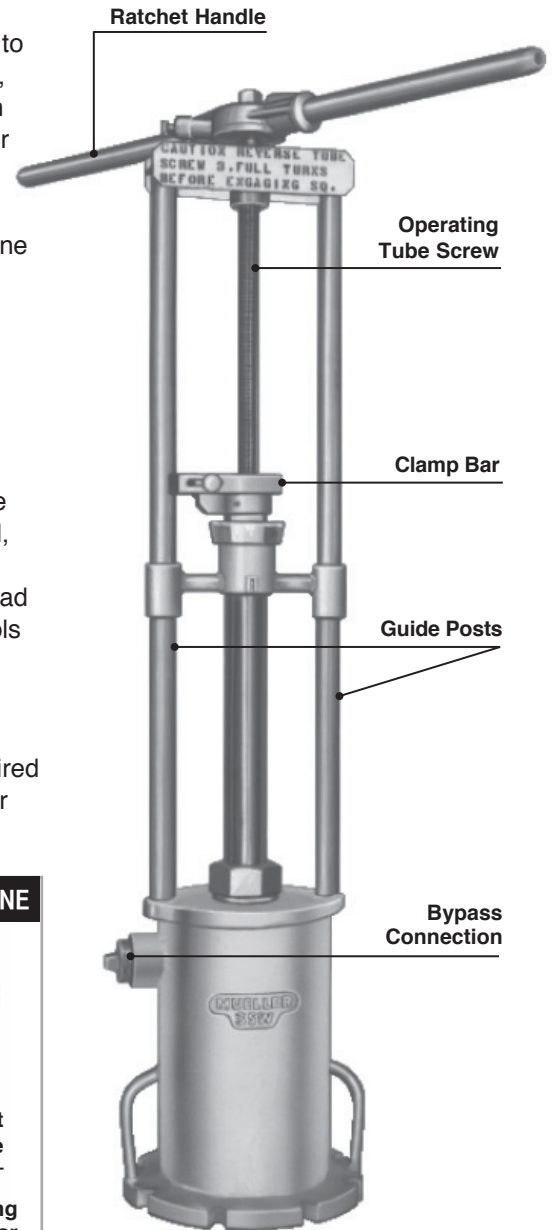

3SW Stopping Machine

Maintenance

Use pipe thread sealant on threads of machines or equipment if required to make a pressure tight threaded connection without using a gasket or O-ring seal.

Keep all machined and threaded surfaces of machines and equipment well lubricated with oil at all times. **DO NOT USE OIL TO LUBRICATE STOPPER COVERS.**

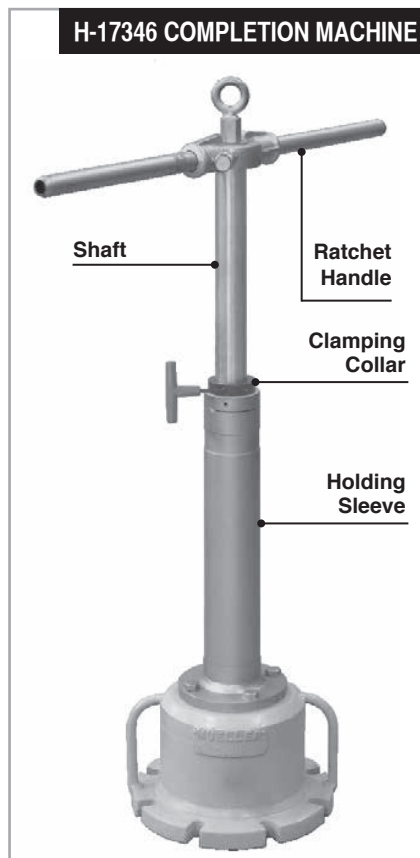

MUELLER® Line Stopper Unit No. 3SW

Installing and Stopping Off 4", 6" and 8" Line Stopper Fittings

Installation

A—Install a Line Stopper Fitting

IMPORTANT: The fitting must be concentric with the center line of the pipe. The fitting should be installed in a vertical position if possible; however, it may be rotated around the pipe to any angle as long as it remains concentric with the axis of the pipe.

TO INSTALL A MUELLER® WELDING LINE STOPPER FITTING (Fig. A), follow instructions 1 – 7.



1. Thoroughly clean the pipe where the fitting is to be attached.
2. Remove completion cap and completion plug from fitting.
3. Place the two halves of the fitting around the pipe. Block up under bottom half of fitting and lower top half onto bottom half. Check to be sure the two halves are in exact alignment with each other. Alignment marks are provided on the fitting halves.
4. Tack weld the four corners of fitting halves together with enough space between the two halves so that they can be rotated around the pipe.
5. Weld both halves of fitting together but free of pipe. The fitting can be rotated so that the side welding is done horizontally on top of the pipe.
6. Locate the fitting in the desired position and weld each end permanently to the pipe.

7. When using bottom-out fittings weld new piping to the bottom opening of the fittings.

TO INSTALL A MUELLER MECHANICAL JOINT LINE STOPPER FITTING (Fig. B), follow instructions 8 – 15.

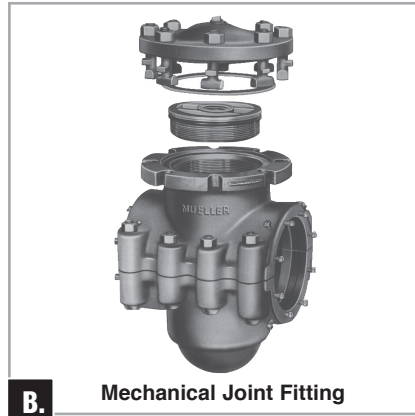

8. Thoroughly clean pipe where fitting is to be installed.
 9. Remove completion cap set screws and completion plug from the fitting. Install the end gasket set screws one half turn past contact with end follower, then install pipe gripping set screw.
- NOTE: On 3" insulated fitting, use the six long set screws on the insulated end for the end gasket set screws.**
10. Separate top and bottom halves of fitting by running off side bolt nuts only. **DO NOT** remove end gaskets, end gasket followers, side bolts, side gaskets or insulator sleeves from fitting.
 11. Back the pipe gripping set screws out enough so they will not interfere with the pipe during the initial installation.
 12. Lubricate rubber gaskets with soapsuds. (Add glycerin in freezing weather) on regular mechanical joint fittings but **DO NOT** lubricate the gaskets on the insulating type fittings as this could reduce the electrical resistance.

13. Place two halves of fitting on pipe, locate fitting in the desired position and tighten side bolts evenly by tightening each one a small amount at a time until each has been tightened to 900 inch-lbs torque.

14. Tighten end screws starting at top and work around the fitting tightening each one a small amount until each has been tightened to 200 inch-lbs torque.

15. Tighten pipe gripping screws evenly a small amount until each has been tightened to 200 inch-lbs torque.

NOTE: Use same procedure on end screws and pipe gripping screws on both regular and insulated fittings.

TO INSTALL AN EXTENSION STOPPER FITTING (Fig. C), follow instructions 16 – 20.



16. Thoroughly clean the pipe to which the fitting is to be attached.
17. Remove cap.
18. Loosen completion plug slightly but **DO NOT** remove. Use completion plug wrench. Latest design of completion plug has an O-ring seal. Loosen this type of plug so that the O-ring is exposed and not in contact with flange of the fitting.

MUELLER® Line Stopper Unit No. 3SW

Installing and Stopping Off 4", 6" and 8" Line Stopper Fittings

19. Attach the fitting to the line at the point where the lateral connection is to be made.

- a) If using an H-17252 fitting with a welding inlet, shape inlet to fit pipe and place it in the desired position and weld it to the pipe line. Reinforce point with split reinforcing saddle if desired.
- b) If using an H-17252 fitting, attach the proper size companion flange to the outlet end of the fitting and bolt the adapter solidly to it. Tack weld the companion flange or block the drilling machine to prevent the companion flange from unscrewing.
- c) If using mechanical joint connections, attach lateral piping to mechanical joint on outlet end of fitting.

20. Install a Save-A-Valve drilling nipple at the extreme end of the new lateral line. This is a purging connection. To install Save-A-Valve drilling nipples, see instruction "I" on page 10.

TO INSTALL A FLANGED TEE (Fig. D), follow instructions 21 – 24.



21. Clean surface where tee is to be welded.

22. Remove completion cap.

23. Loosen completion plug slightly but DO NOT remove. Use completion plug wrench. Latest design of completion plug has an O-ring seal. Loosen this type of plug so that the O-ring is exposed and not in contact with the flange of the tee.

24. Locate the tee in the desired position and weld to the pipe.

NOTE: It may be necessary to shape the inlet end of the tee to fit the pipe when used on larger size pipe. The tee may be installed in any position, providing that the center line of the tee is at a right angle to the axial center line of the pipe. A vertical position is recommended if condition will permit. A modified split reinforcing saddle may be used if desired.

NOTE: Raising the tee up off the main may adversely affect drilling travel.

TO INSTALL A MUELLER FLANGED SAVE-A-VALVE (Fig. E), follow instructions 25 – 28.



NOTE: The work may be scheduled so that much of this equipment will be available for other jobs such as the installation of line stopper fittings. The gate valve (part number 83953) from the H-17340 stopping machine and the valve adapter (if required) will not be available for other work during the time that the nipple is in use.

Weld the nipple to the pipe.

25. Clean surface where nipple is to be welded.

26. Remove completion cap.

27. Loosen completion plug slightly but DO NOT remove. Use completion plug wrench. Latest design of completion plug has an O-ring seal. Loosen this type of plug so that the O-ring is exposed and not in contact with the flange of the nipple.

28. Locate the nipple in the desired position and weld to the pipe.

NOTE: It may be necessary to shape the inlet end of the nipple to fit the pipe when used on larger size pipe. The nipple may be installed in any position providing that the center line of the nipple is at a right angle to the axial center line of the pipe. A split reinforcing saddle may be used if desired.

B—Attach Lateral Piping

1. Weld lateral piping to outlet of tee.
2. Extend the lateral piping to the next valve or shut-off point and close this valve.
3. Pressure will be applied to the new line when the stopper is contracted. New line may be purged of air from the purging connection (Save-A-Valve drilling nipple) installed at extreme end of new lateral line.

C—Test Installation

1. Bolt completion cap to tee, fitting, or Save-A-Valve ensuring gasket is in good condition and in place. Remove test plug in completion cap and attach air hose.
 - a) Apply air pressure and test for leaks with soapsuds.
2. Remove test cap. If completion cap was used for testing, replace test plug in completion cap.

MUELLER® Line Stopper Unit No. 3SW

Installing and Stopping Off 4", 6" and 8" Line Stopper Fittings

D—Attach Gate Valve

1. Gate valve is a special 9¹/₄" Mueller gate valve, for use with 4", 6" and 8" line stopper fittings, flanged tees and flanged Save-A-Valves. Valve must be installed with rubber-faced disc up since pressure aids in seating the gate and keeping it tight when closed.
2. Attach gate valve to tee, fitting, Save-A-Valve or valve adapter.
 - a) 8" tees, Save-A-Valves and line stopper fittings having class 150 flanges do not require a valve adapter between the tee or fitting and gate valve. Check to be sure the gasket is in good condition and in place. The bolt nuts should be loose at this point to permit the gate valve to be shifted slightly if necessary.
 - b) All 4", 6" and 8" tees, Save-A-Valves and fittings having class 300, 400 or 600 flanges require a valve adapter between the fitting and the valve. At both of these flanged joints, check to be sure the gaskets are in good condition and in place. The bolt nuts for both joints should be loose at this point to permit gate valve and valve adapter to be shifted slightly if necessary.
3. Open gate valve, check to be sure it is fully open (approximately 30 turns to open).
4. Turn bypass stop on gate valve to bypass position (check screw in upper position).
5. Attach plug alignment tool to completion plug.
 - a) Push fork to rearmost position and tighten thumb screw.
 - b) Screw the end of the tool into the inside threads in the top of the completion plug.
 - c) Loosen thumb screw so that the fork lugs will engage with the slots in the completion plug.

6. Attach plug alignment tool with the completion plug attached to it to the shaft of the completion machine.
 - a) Remove protector nut from end of shaft.
 - b) Insert lug on shaft into matching recess or slot in plug alignment tool.
 - c) Screw coupler sleeve on plug alignment tool to shaft threads.
7. Withdraw completion machine shaft and tighten holding clamp.
8. Attach completion machine to gate valve. It is not necessary to use all the bolts at this point.
9. Hold completion machine shaft and loosen holding clamp, slowly lower holding sleeve into position and advance shaft until completion plug contacts fitting threads.

IMPORTANT: DO NOT let shaft drop.
10. At this point it may be necessary to slightly shift the gate valve on the fitting and possibly the completion machine on the gate valve to align the completion plug threads with the fitting threads.
11. Rotate shaft **clockwise** until completion plug threads are engaged with fitting threads at least 1/2".
12. Securely bolt gate valve to fitting (or gate valve to valve adapter and valve adapter to fitting) and mark the position of the completion machine flange location in relation to the gate valve flange. This is for reference so that the completion machine may be properly positioned for the final installation of the completion plug when the job is finished.
13. Rotate shaft **counter-clockwise** until completion plug is unscrewed from fitting. Withdraw shaft to rearmost position, raise sleeve and place pin in sleeve.
14. Remove completion machine from gate valve.

15. Hold back on shaft and sleeve, loosen holding clamp and advance shaft until completion plug and plug alignment tool are exposed.

16. Remove completion plug and plug alignment tool from shaft and place protector nut on end of shaft.

17. Remove plug alignment tool from completion plug.

E—Attach and Operate Drilling Machine

For detailed instructions, see Operating Instructions for Mueller C1-36 Drilling Machines.

1. Sharpen shell cutter and pilot drill before each cut by honing the front edge of the cutter teeth. If the shell cutter is dull, it should be returned to Mueller Co., Decatur, Illinois for reconditioning. Check pilot drill detents to be sure they operate correctly.
2. Bolt drilling machine adapter to the front of drilling machine. Check to be sure that gasket is in good condition and in place.
3. Release automatic feed by pulling out automatic feed knob. (Directions are indicated on panel on rear of torque tube.)
4. Advance boring bar by rotating feed crank **counter-clockwise** until bolt hole in boring bar is exposed beyond face of adapter. (Directions are indicated on panel on rear of torque tube.) Remove hub-retaining bolt.
5. Assemble drilling equipment.
 - a) When using C1-36 drilling machines, assemble the shell cutter and cutter hub. Insert the shank of pilot drill into the socket in the boring bar. Slide cutter hub and shell cutter over the end of the boring bar. Align holes in the cutter hub, boring bar and pilot drill and attach to boring bar with hub retaining bolt.

MUELLER® Line Stopper Unit No. 3SW

Installing and Stopping Off 4", 6" and 8" Line Stopper Fittings

6. Retract boring bar to rearmost position by rotating feed crank **clockwise**. Measure to verify the pilot drill does not protrude more than 3" beyond the machine adapter, otherwise the drill could interfere with closing the gate valve later in the procedure.

7. Place the machine (with adapter and drilling equipment assembled) in drilling position on gate valve and bolt adapter solidly to valve flange. Check to be sure that the gasket is in good condition and in place.

8. Be sure that the welded fitting is cool before cut is started.

9. Rotate feed crank **counter-clockwise** to advance boring bar until pilot drill contacts the main. One turn of the feed crank moves boring bar 1/8" (4 mm) – 6 revolutions equals 1" (25 mm). For C1-36-99002 machine, 8 revolutions equal 1" (25 mm). Back up boring bar 1/4 turn of feed crank **clockwise** to release tension between pilot drill and main.

10. Set feed indicator to zero. Mark the point on feed indicator shield that the arrow will reach to complete the cut.

11. Engage automatic feed by pushing in on automatic feed knob.

12. Operate the drilling machine. When using the C1-36 Machine and a MUELLER Air or Hydraulic operated motor:

a) Loosen the pivot set screw. This permits pivot pin to be removed so that air motor holder may be attached to the holder pivot on the drive box of the drilling machine. Position air motor holder and replace pivot pin. Tighten the pivot set screw and latch the small hook on the air motor holder to the pin on the machine drive box to prevent movement of the air motor holder. Examine air motor on ground with air pressure on. Position throttle lever for forward operation, this will turn drive spindle **clockwise**.

b) Place air motor in holder, open throttle slightly. Spindle will turn until square in motor spindle aligns with square spindle. Motor will then drop into place. Screw feed screw in top of motor back into countersink in top of holder. Slide hook clamp into position on air motor torque handle and tighten.

c) Open air motor throttle fully so that motor is operating at proper speed (50 to 60 rpm).

IMPORTANT: Maintain pressure of 90 psi. We recommend the use of a gage at the throttle to determine the actual pressure of air at the air motor.

If cutting becomes difficult and motor stalls, see detailed instructions for the C1-36 Machine.

d) When drilling through bottom-out fittings, purge air from new bottom-out line by opening the downstream gate valve slightly when the pilot drill penetrates the bottom of the pipe through the upstream fitting. The bypass stop on the gate valve should be in the closed position.

13. Continue the cutting operation until the pipe is cut completely through and the arrow reaches the point marked on the feed indicator shield, or until the cutter stops cutting. If power is being used, shut off motor.

14. Check completion of cut by releasing automatic feed and attempting to advance cutter

by rotating feed crank **counter-clockwise**. If it does not advance easily, the cut is not completed and automatic feed knob must be pushed in for further cutting.

⚠ CAUTION: Stop advancing the boring bar when the limit line on the boring bar becomes visible through the drive box drain hole.

15. When cut is completed, release automatic feed and retract cutter to its rearmost position by rotating feed crank **clockwise**.

F—Remove Drilling Machine

1. Fully close gate valve (approximately 30 turns).

2. DO NOT force valve closed as that may destroy the rubber seat of the valve.

3. Turn bypass stop to test position (check screw in middle position). This exhausts the pressure above the gate and also indicates whether or not the gate is shut tightly.

4. Remove bolts from the joint between the gate valve flange and the drilling machine adapter flange. Remove the drilling machine and drilling machine adapter from the gate valve as a unit.

5. Advance boring bar by rotating feed crank **counter-clockwise** until hub retaining bolt is exposed beyond face of adapter. (Directions are indicated on rear cover of torque tube.)

6. The drilling operation cuts completely through the pipe removing 2 sections of pipe on line stopper fittings. One coupon is removed from the top of the pipe and a second coupon is removed from the bottom of the pipe. These two cut-out sections of pipe are held inside the shell cutter by the pilot drill. Remove hub retaining bolt, cutter hub and pilot drill from the boring bar of the machine.

NOTE: Only one coupon is cut on Flanged Tees and Save-A-Valves.

Size and Kind of Pipe	From Point of Pilot Drill Contact on Pipe	From Point of Shell Cutter Contact on Pipe
3" Steel*	5 ⁵ / ₈ "	3 ³ / ₄ "
4" Steel	6 ¹ / ₂ "	4 ³ / ₄ "
4" Steel*	6 ⁵ / ₈ "	4 ³ / ₄ "
4" Cast Iron	6 ⁷ / ₈ "	5 ¹ / ₈ "
6" Steel	8 ⁵ / ₈ "	3 ⁷ / ₈ "
6" Steel*	8 ⁵ / ₈ "	6 ⁷ / ₈ "
6" Cast Iron	9"	7 ¹ / ₄ "
8" Steel	10 ⁵ / ₈ "	8 ⁷ / ₈ "
8" Cast Iron	11 ¹ / ₈ "	9 ³ / ₈ "

Above dimensions include 1/4" of overtravel.

*For H-17268 Fittings.

MUELLER® Line Stopper Unit No. 3SW

Installing and Stopping Off 4", 6" and 8" Line Stopper Fittings

7. Remove the pilot drill from the cut-out section of pipe.

8. Remove the cut-out sections of pipe from inside the shell cutter by sliding them straight forward one at a time. Insert two screw drivers in the holes in the shell cutter and pry evenly against the cut out sections of pipe to aid in sliding them forward. (If the cut-out section tilts it may bind on the inside of the cutter.)

9. See page 15 for using the H-17619 Inspection Flange.

G—Attach Stopper to Stopping Machine

1. Attach combined crank and lifting yoke to Mueller® stopping machine.

2. Rotate crank **counter-clockwise** until operating tube and guide tube are exposed.

3. Remove stopper from protector sleeve by turning square end of expander screw **counter-clockwise** until stopper is free from protector sleeve.

4. Check stopper to be sure it is fully contracted. Lower conical expanding wedge should be positioned against slotted nut on bottom of expander screw. Be sure expander screw threads in stopper are well lubricated.

5. Attach stopper to stopping machine.

- Insert square on expander screw into operating tube.
- Align lug on top expanding wedge with matching recess or slot in end of guide tube.
- Slide stopper coupler nut into position over top expanding wedge threads and tighten securely by hand.

NOTE: Early models of the stoppers were made with a hole drilled through the square of the expander screw permitting

the operating tube to be pinned to the stopper with a stopper coupler screw. This screw was used to limit turning the expander screw too far to the left (when contracting the stopper) thus preventing the bottom expanding wedge from unscrewing and dropping off into the bottom of the fitting.

Improvements in construction cause the expander screw to be made slightly longer and a lock nut is screwed on the bottom and secured in place with a cotter pin. Since there is no longer any possibility of accidentally disassembling the stopper, the hole in the square and the stopper coupler screw for new stoppers and stopping machines have been eliminated.

Old style stoppers are easily identified due to the hole in the square on the expander screw and later style by its absence.

New style stoppers can be used with both new style and old style stopping machines. However, if used with old style stopping machines, the stopper coupler screw is not used. Old style stoppers cannot be used with new style stopping machines.

If old style stoppers are to be used with old style stopping machines, a stopper coupler screw must be used.

When old style machines are used with old style stoppers, it is necessary to remove stopper coupler screw, insert stopper shaft in operating tube shaft, align the holes and insert the stopper coupler screw. The screw must be flush or below flush with outside of operating shaft. Stopper may then be secured by the use of the stopper coupler nut.

6. Lubricate stopper cover with Mueller rubber stopper lubricant.

7. Retract stopper to rearmost position by rotating crank **clockwise**.

H—Attach Stopper to Gate Valve

1. Position stopping machine on gate valve. **For best stop-off operation of stopper, bypass connection in stopping machine body should always face the section of pipe to be stopped off.**

Stopper may be reversed at some loss in shut-off effectiveness. Bolt stopping machine to gate valve with gasket between valve and stopping machine.

2. Follow these instructions when using two stopping machines to isolate a section of pipe and using an integral bypass line to maintain service (**Fig. F**). For flow data, refer to www.muellergas.com Engineering Information.

- Assemble a bypass line between the bypass connections of stopping machines.
- Install Save-A-Valve® drilling nipple on the section of pipe to be stopped off near the downstream stopping machine (stopping machine near the source of pressure). This is a purging connection.

3. Follow these instructions when using two stopping machines to isolate a section of pipe using a separate bypass line to maintain service (**Fig. G**).

- Install a Save-A-Valve® drilling nipple on the pressure side of each stopping machine. Connect these two nipples to form a bypass line around the two stopping machines and the section of pipe to be stopped off.
- Install a third Save-A-Valve drilling nipple in the section of the pipe to be stopped off near the downstream stopping machine (stopping machine away from the source of pressure in the pipe). This nipple will be used as a purging connection and blow-down connection.
- Tighten the plugs in bypass connections of the stopping machine bodies.

MUELLER® Line Stopper Unit No. 3SW

Installing and Stopping Off 4", 6" and 8" Line Stopper Fittings

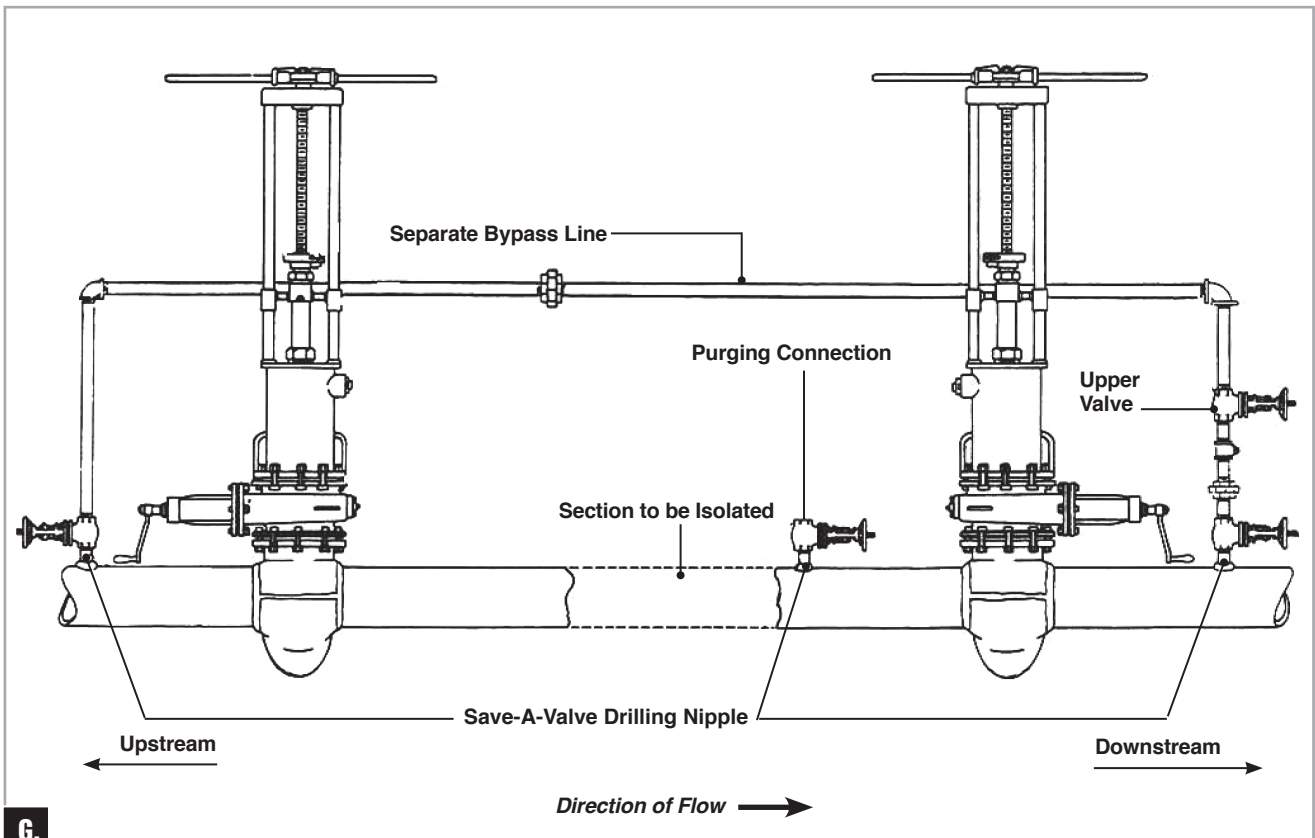
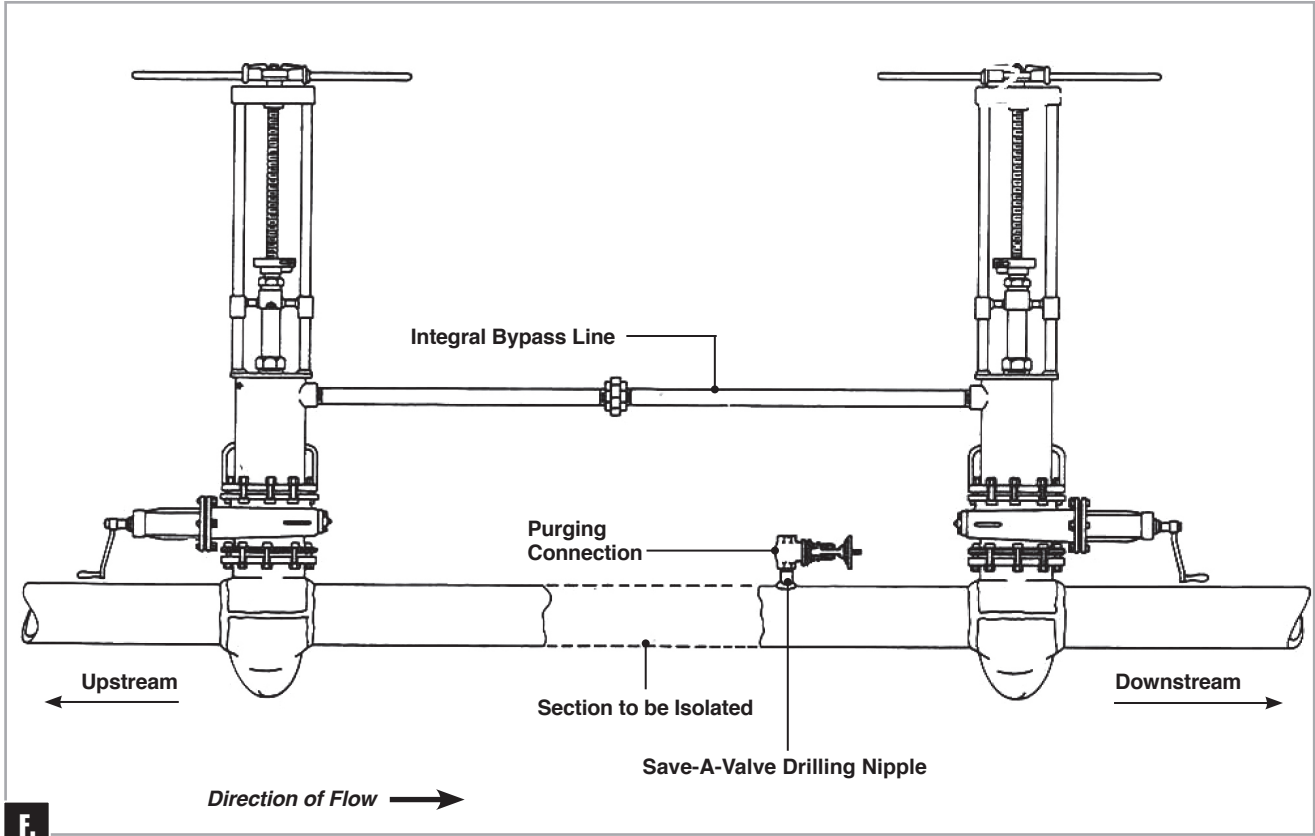

MUELLER® Line Stopper Unit No. 3SW

Installing and Stopping Off 4", 6" and 8" Line Stopper Fittings

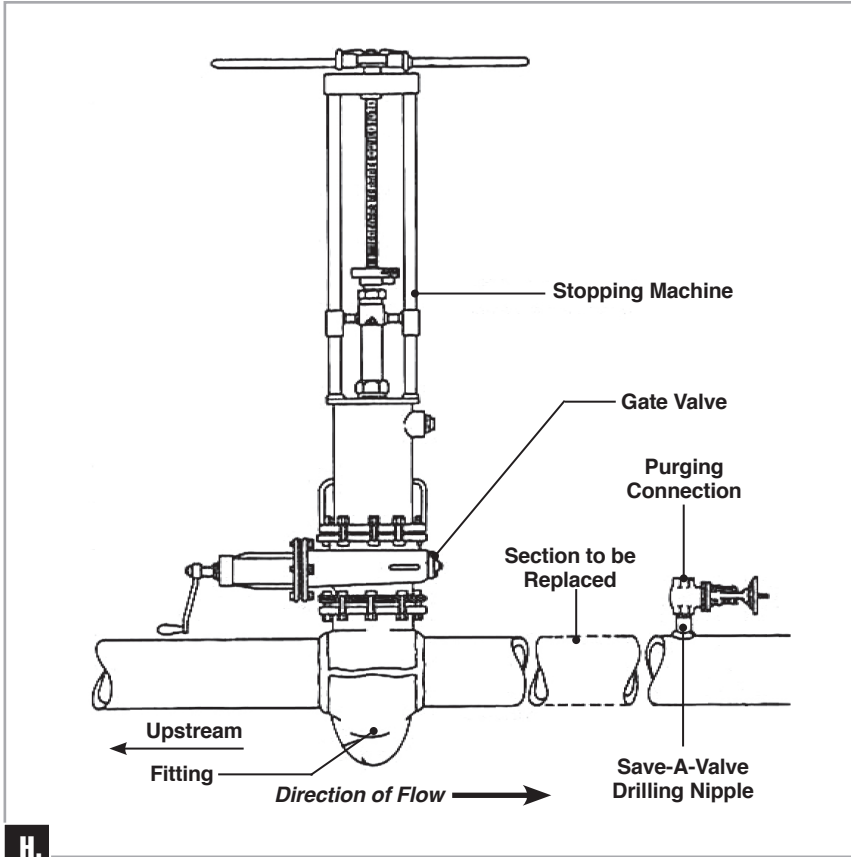

4. When using one stopping machines to stop off pipe (**Fig. H**).

- Install a Save-A-Valve® drilling nipple on the stopped off side of the stopping machine. This nipple will be used as a purging connection.
- Tighten the plug in bypass connection of the stopping machine body.

5. When using two stopping machines to stop off a section of pipe and maintain service through bottom-out line (**Fig. I**).

- Install a Save-A-Valve drilling nipple on the section of pipe to be stopped off near the downstream stopping machine (stopping machine away from the source of pressure). This is used to blow down the this section before removing.
- The bottom-out line serves as a bypass connection.
- Tighten the plug in bypass connection of the stopping machine.

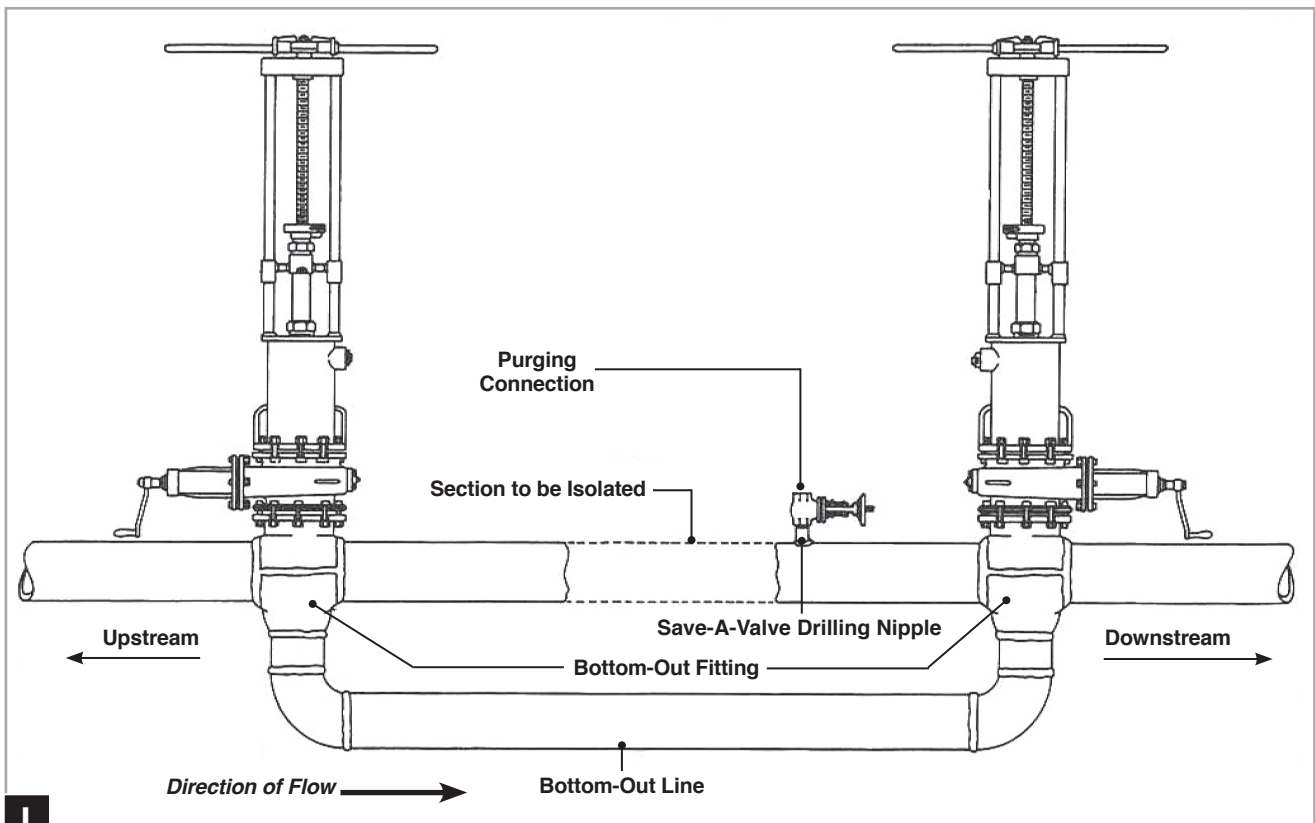

MUELLER® Line Stopper Unit No. 3SW

Installing and Stopping Off 4", 6" and 8" Line Stopper Fittings

I—Installation of Save-A-Valve® Drilling Nipples 3" and Smaller (Fig. J). (See Mueller Gas Distributions Products Catalog for machines and equipment to perform this operation.)



1. Clean surface of pipe where nipple is to be welded or service clamps attached.
2. Remove cap and plug before welding.
3. Place nipple in position and weld to pipe or service clamp and attach nipple to clamp.
4. Screw test cap to nipple. Apply air pressure and test for leaks using soapsuds or a leak detection fluid. (Add glycerin to soapsuds in freezing weather.)
5. Remove test cap and attach Mueller gate valve. Open gate valve fully. (The smaller size drilling nipples require a bushing between the nipple and gate valve.)
6. Attach proper size machine adapter nipple and drilling tools to Mueller T-W, E-5, D-5, EH-5 or DH-5 Drilling Machine. For detailed instructions, see operating instruction books for these machines.
7. Apply a small amount of Mueller cutting grease to leading edge of drill and/or shell cutter.

8. Place drilling machine and adapter nipple on gate valve and tighten drilling machine adapter nipple into gate valve.
9. Advance boring bar until drill contacts pipe, then retract boring bar a small amount.
10. Start drilling operation. When hand operating the drilling machine, begin with a light, even feed, then a heavier feed, then finish drilling with a light even feed.
11. Continue drilling until hole is completely drilled (This can be determined by feel of feeding mechanism or by measuring advance of boring bar).
12. After drilling is complete, retract boring bar to its rearmost position so that the drill safely clears the valve gate.

⚠ CAUTION: When this machine is under pressure, control the piston action of the boring bar to prevent bodily injury or damage to the machine.

13. Close gate valve.
14. Remove drilling machine and machine adapter from gate valve.

J—Place Bypass Line in Operation

1. If integral bypass line is being used between two stopping machines (Fig. F), purge air from bypass line by:
 - a) Turn bypass stop on upstream stopping machine gate valve to bypass position (check screw in upper position).
 - b) Open upstream stopping machine gate valve slightly.
 - c) Turn bypass stop on downstream stopping machine gate valve to test position to purge air from bypass line and stopping machine (check screw in middle position). When air is purged from bypass line and machines, turn bypass stop to bypass position (check screw in upper position). Pressure will now build up in bypass line.

- d) Open both stopping machine gate valves fully. Bypass line is now in operation.

2. If separate bypass line is being used (Fig. G), purge air from bypass line by:

- a) Remove the plug from the tee in the bypass line.
- b) Open gate valve on upstream bypass connection slightly.
- c) Open upper valve in bypass line until all air is purged from bypass line, then close upper valve in bypass line.
- d) Replace plug in tee in bypass line and open gate valve on downstream bypass connection slightly.
- e) Open upper valve in bypass line. Pressure will now build up in bypass line.
- f) Open gate valves fully on both upstream and downstream bypass connections. Bypass line is now in operation.

3. When using bottom-out fittings and bottom-out line, the bottom-out line is used as the bypass line and is already in operation.

K—Insert Stopper Into Fitting

NOTE: When using a bypass line to maintain service around stopping machines and section of pipe to be stopped off, insert and expand an upstream stopper first.

1. Open bypass valve on gate valve. Be sure blow-off valve is closed.
2. Open stopping machine gate valve fully. Advance stopper by rotating crank (or double handled ratchet) **counter-clockwise** until squared section on operating tube screw is exposed. **Advance carefully until stopper contacts bottom of Mueller® fitting. DO NOT force stopper against bottom of fitting since this is merely a positioning operation.**

MUELLER® Line Stopper Unit No. 3SW

Installing and Stopping Off 4", 6" and 8" Line Stopper Fittings

IMPORTANT: Rotate crank (or double handled ratchet) clockwise three full turns to provide adequate clearance for free expansion of stopper.

L—Expand Stopper Into Fitting

1. Loosen wing nut and shift clamp bar from contact with guide post to contact with squared section of operating tube screw. This places expanding mechanism in operation. Tighten wing nut.
2. If crank has been used to insert stopper, replace it with double handled ratchet.
3. Set ratchet dog for **clockwise** rotation and rotate ratchet to expand stopper. Approximately 6 or 7 revolutions will effect a shut-off depending upon the line pressure being shut-off and condition of stopper seating surface in fitting.
4. With both stoppers expanded, open gate valve on Save-A-Valve drilling nipple used as a purging connection and blow down the stopped-off section of pipe (stopper tightness will also be indicated at this point).
5. Proceed with work to be done on stopped-off section of pipe.

NOTE: When cutting or welding near line stopper fittings containing stoppers, maintain the following minimum distance to prevent damage to stopper:

- 3" & 4" fitting - min. distance 12"
- 6" fitting - min. distance 14"
- 8" fitting - min. distance 16"

If this distance cannot be maintained, use wet burlap or rags around fitting to keep temperature down. If stopped-off section of pipe is being torch-cut, refer to Form 12666 for minimum distance and guidelines.

6. When using bottom-out fittings, cut off and remove isolated section of pipe. Weld caps on stub ends of pipe.

M—Contract Stopper Into Fitting

1. When all desired work has been done on stopped-off section of pipe, check to be sure all welded joints are cool.
2. Contract upstream stopper first. Set ratchet dog for **counter-clockwise** rotation and rotate ratchet the same number of turns as required to stop-off the line, or until the ratchet handle comes to a solid stop.
3. After stopper reaches the limit of **counter-clockwise** rotation, reverse ratchet dog and rotate handle approximately one turn **clockwise**. This releases tension on lower wedge retaining nut (or the stopper coupler screw, if previous design of machine is being used) and permits easy removal later.
4. Open gate valve on purging connection until all air has been purged from stopped-off section. Close this gate valve.
5. Test all joints when pressure has built up in section that was stopped-off.
6. Contract downstream stopper.

N—Extract Stopper from Fitting

1. Loosen wing nut and shift clamp bar from contact with squared section of operating tube screw to contact with guide post, then tighten wing nut.
2. Rotate ratchet handle (or replace with crank handle) **clockwise** to retract stopper to rearmost position.
3. Close stopping machine gate valves.

4. Turn bypass stops on gate valves to test position (check screw in middle position). Flow from bypass stops will blow down bypass line. When using a separate bypass line, close gate valves on upstream bypass connection and downstream bypass connection. Close upper valve in bypass line. Remove plug from tee in bypass line and open upper valve in bypass line.
5. Remove bypass line and stopping machines.

O—Plug and Cap the Save-A-Valve Drilling Nipples

(See Mueller Gas Distributions Products Catalog for machines and equipment to perform this operation.)

1. Thread drilling nipple completion plug to inserting tool of the Mueller E-5, EH-5, D-5 or DH-5 Drilling Machine. Lubricate these threads and check to be sure that these threads screw together freely without binding.
2. Apply non-hardening pipe thread sealant to plug threads.
3. Attach drilling or completion machine to gate valve.
4. Open gate valve, advance boring bar and screw completion plug into drilling nipple securely by rotating boring bar **clockwise**.
5. Remove inserting tool from plug by turning handle **counter-clockwise** to take up slack and striking handle of the machine a sharp now be free to turn.
6. Rotate **counter-clockwise** until inserting tool is free from plug.
7. Remove drilling machine or completion machine) and gate valve.
8. Tighten plug with wrench.
9. Apply pipe thread sealant to completion cap threads and thread cap tightly to the nipple. Test for leaks with soap solution. (Add glycerin in freezing weather.)

MUELLER® Line Stopper Unit No. 3SW

Installing and Stopping Off 4", 6" and 8" Line Stopper Fittings

P—Install Completion Plug in Line Stopper Fitting

NOTE: Latest design completion plugs have an O-ring seal and a pressure equalizing valve in the center of the completion plug. The end of the inserting or extracting tool will open the equalizing valve.

1. Hold back on completion machine shaft and loosen holding clamp. Advance shaft of completion machine.
2. Attach plug-inserting tool to the completion plug.
 - a) Push fork of inserting tool to rearmost position.
 - b) Hold fork in this position and screw the end of inserting tool into the inside threads in the top of the completion plug.
 - c) Check to be sure inserting tool has opened equalizing valve.
 - d) Release fork so the fork lugs will engage with the slots in the completion plug. This may require backing off inserting tool slightly.
3. Attach plug-inserting tool with the completion plug assembled to the shaft of completion machine.
 - a) Remove protector nut from end of shaft.
 - b) Insert lug on shaft into matching recess or slot in plug inserting tool.
 - c) Screw coupler sleeve on plug inserting tool to shaft threads.
4. Coat the threads and O-ring on completion plug with a heavy grease.
5. Withdraw shaft to rearmost position and tighten holding clamp.
6. Place completion machine on gate valve in same position as marked in the alignment operation, paragraph "C-10". With gasket in place, bolt completion machine solidly to gate valve.
7. Fully open gate valve.

8. Hold back on completion machine shaft and loosen holding clamp. Slowly advance shaft and thread completion plug into fitting by rotating the shaft **clockwise**.

NOTE: DO NOT let shaft drop.

9. Remove plug-inserting tool from completion plug by turning shaft **counter-clockwise**.
10. Turn bypass stop to test position (check screw in middle position) to determine tightness of plug.
11. Unbolt and remove completion machine and gate valve from fitting as a unit.
12. Completion plugs furnished with an O-ring will be tightened to their seat by the machine with no further tightening needed. For plugs without O-rings, tighten completion plug with completion plug wrench. Place a pipe or rod through the wrench to aid in tightening the completion plug.
13. Place gasket in fitting recess and put completion cap in place.
14. Bolt cap solidly to fitting flange.
15. Test fitting again with soapsuds.
16. Refill trench.

Q—Future Removal of Completion Plug

1. Remove completion cap.
2. Examine the completion plug to determine whether or not it has an equalizing valve. The equalizing valve is located in center recess.
3. If completion plug does not have an equalizing valve, loosen the plug slightly using completion plug wrench.
4. Bolt the gate valve to the fitting.
 - a) 8" line stopper fittings having class 150 flanges do not require a valve adapter between the fitting and gate valve. Check to be sure the gasket is in good condition

and in place. The bolt nuts should be loose at this point to permit the gate valve to be shifted slightly if necessary.

- b) All 4", 6" and 8" tees, fittings, and Save-A-Valves having class 300, 400 or 600 flanges require a valve adapter between the fitting and the valve. At both of these flanged joints check to be sure the gaskets are in good condition and in place. The bolt nuts for both joints should be loose at this point to permit gate valve and valve adapter to be shifted slightly if necessary.
 5. Open gate valve fully.
 6. Turn bypass stop to test position (check in middle position).
 7. Attach plug alignment tool to shaft of completion machine.
 - a) Remove protector nut from end of shaft.
 - b) Insert lug on shaft into matching recess or slot in plug alignment tool.
 - c) Screw coupler sleeve on plug alignment tool to shaft threads.
 - d) Push the fork on plug alignment tool to rearmost position and tighten thumb screw to hold the fork in this position .
 8. Withdraw shaft to rearmost position. Raise sleeve and place pin through hole in sleeve to prevent the shaft from falling while completion machine is being placed on gate valve.
 9. Attach completion machine to gate valve. It is not necessary to use all the bolts at this point.
 10. Hold back on completion machine shaft and loosen holding clamp. Slowly advance shaft until plug alignment tool contacts completion plug.
- IMPORTANT: DO NOT let shaft fall.**

MUELLER® Line Stopper Unit No. 3SW

Installing and Stopping Off 4", 6" and 8" Line Stopper Fittings

11. At this point, it may be necessary to slightly shift gate valve on the fitting or the completion machine on the gate valve to align the plug alignment tool with the completion plug threads.

12. Rotate shaft **clockwise** until plug alignment tool threads are engaged with thread in the completion plug.

13. Securely bolt gate valve to the fitting. Mark the position of completion machine flange in relation to gate valve flange. This is for reference so completion machine can be properly positioned for final installation of completion plug when the job is finished.

14. Rotate shaft **counter-clockwise** until plug alignment tool is unscrewed from threads in the completion plug.

15. Withdraw shaft to rearmost position and tighten holding clamp.

16. Remove completion machine from gate valve.

17. Hold back on completion machine shaft and loosen holding clamp. Advance shaft until completion plug tool is exposed.

18. Remove plug alignment tool from shaft.

19. Attach plug extracting tool to shaft of completion machine.

a) Insert lug on shaft of completion machine into matching recess or slot in plug extracting tool.

b) Screw coupler sleeve on plug extracting tool to shaft threads.

20. Withdraw shaft to rearmost position and tighten holding clamp to prevent the shaft from falling while completion machine is being placed on gate valve.

21. Place completion machine on gate valve in same position as marked in paragraph "L-10".

22. Hold back on completion machine shaft and loosen holding clamp. Slowly advance shaft until plug extracting tool contacts the completion plug.

23. Rotate shaft **clockwise** until plug extracting tool is firmly threaded into top of completion plug.

24. If the completion plug has an equalizing valve, it will be opened by the end of the extracting tool. Flow from the bypass stop on gate valve will indicate that equalizing valve is open. Turn bypass stop to bypass position (check screw in upper position).

IMPORTANT: DO NOT attempt to remove completion plug until pressure is equalized.

25. Rotate shaft **counter-clockwise** until completion plug is unscrewed from the fitting.

26. Withdraw shaft to rearmost position and tighten holding clamp. Check to be sure that the completion plug clears the valve gate.

27. Close gate valve and test for tightness by turning bypass stop to test position (check screw in middle position).

28. Remove completion machine from gate valve.

29. Hold back on completion machine shaft and loosen holding clamp. Advance shaft until completion plug and plug extracting tool are exposed.

30. Remove completion plug and plug extracting tool from shaft and place protector nut on end of shaft.

31. Refer back to instruction "F" and proceed with the use of the fitting.

Flanged Tee Stopper Installation

Pressure Ratings:

083506 – 4" Flanged Tee Stopper – Maximum Pressure Rating 250 psig. 528161 adapter bushing required for use with 3SW equipment.

682337 – 6" Flanged Tee Stopper – Maximum Pressure Rating 250 psig. Older style 083507 cannot be used with 3SW equipment.

682339 – 8" Flanged Tee Stopper – Maximum Pressure Rating 200 psig. Older style 083508 cannot be used with 3SW equipment.

1. Determine proper equipment required for the stop-off operation from the Mueller Gas Distribution Products Guide.
2. Remove completion cap. Attach required equipment and remove completion plug from tee.
3. Inspect stopper to assure that resilient sealing surface is in good condition. Apply Mueller Rubber Stopper Lubricant (P/N 580657) to the rubber seal.
4. Securely attach stopper to the stopping machine (using the appropriate adapter, if one is required) and retract bar to its rearmost position.
5. Attach stopping machine to gate valve.
6. Pressurize the machine above the gate valve by using the bypass valve on the gate valve.
7. Open the gate valve fully.
8. Lower stopper into tee by turning stopping machine handle in the **counter-clockwise** direction until stopper is seated and fully expanded. A gage and/or test nipple is recommended on the section of main to be isolated to determine when gas flow has been completely stopped.
9. Blow down the isolated section of main and check for a complete shut-off. If shut-off is not complete, continue to compress the stopper until shut-off is satisfactory.
10. Complete repairs to the branch line as required and test for leaks using an accepted practice.
11. When ready to restore gas flow: slowly turn crank handle **clockwise** to relax the rubber seal and allow gas flow into isolated section until pressure is equalized. Purge air from isolated section.
12. Continue turning crank handle in **clockwise** direction to fully unseat stopper and retract machine bar and stopper to rearmost position above gate valve.
13. Close gate valve.
14. Blow down pressure in stopping machine by turning bypass relief valve to relief position.
15. Remove stopping machine.
16. Attach completion machine to gate valve and install completion plug into tee.
17. Install completion cap and perform finishing procedures.

⚠ CAUTION: DO NOT raise stopper until rubber plug is fully relaxed and pressure is equalized.

MUELLER® Line Stopper Unit No. 3SW

Calculating Number of Turns to Contact Main / Using H-17619 Inspection Flange

Calculating C1-36 Turns

1. Fully retract shell cutter and pilot drill into C1-36/C1-36-99002 drilling machine adapter.
2. Determine if tip of pilot drill is sticking out past the machine adapter or recessed inside.

Pilot tip past drilling machine adapter flange face:

1. Measure the distance from face of the top gate valve flange to the top of the pipe.

Record this distance in inches. (A)

2. Measure distance pilot tip is past the drilling machine flange face.

Record this distance in inches. (B)

3. Subtract distance (B) from distance (A) to achieve travel (T) distance to top of main.

4. For a standard feed 6:1 C1-36 machine, multiply this distance (T) by 6 to achieve total number of turns to hand advance to contact the main.

5. For a slow feed 8:1 C1-36-99002 machine, multiply this distance (T) by 8 to achieve total number of turns to hand advance to contact the main.

Pilot tip recessed inside drilling machine adapter flange face:

1. Measure distance from the face of the top gate valve flange to the top of the pipe.

Record this distance. (A)

2. Measure the distance pilot tip is recessed inside drilling machine adapter flange face.

Record this distance. (B)

3. Add distance (A) & (B) to achieve travel distance (T) to contact top of main.

4. For a standard feed 6:1 C1-36 machine, multiply this distance (T) by 6 to achieve total number of turns to hand advance to contact the main.

5. For a slow feed 8:1 C1-36-99002 machine, multiply this distance (T) by 8 to achieve total number of turns to hand advance to contact the main.

Using H-17619 Inspection Flange

The H-17619 Inspection Flange is for visually determining the condition of the inside of the Line Stopper Fitting and the inside of the pipe after the drilling operation is completed. This may be done under pressure (**Fig. K**).

1. Bolt drilling machine adapter (part no. 365451) to gate valve. Check to be sure gasket is in good condition and in place.
2. Bolt H-17619 Inspection Flange to drilling machine adapter. Check to be sure gasket is in good condition and in place.
3. Turn bypass stop to bypass position (check screw in upper position).
4. Open gate valve fully.

5. Visually examine the inside of the fitting by viewing through the plastic window. Use a flashlight or spot light.

6. Use the retrieving rod to locate raise and hold above the gate valve any object which might interfere with the operation of the stopper such as a section of the pipe. The retrieving rod has a ball-joint type of pressure seal permitting it to be raised, lowered, rotated or moved from side to side.

7. Tighten sleeve screw to hold retrieving rod in raised position.

8. Close gate valve and test for tightness by turning bypass stop to test position (check screw in middle position).

9. Remove drilling machine adapter and inspection flange.

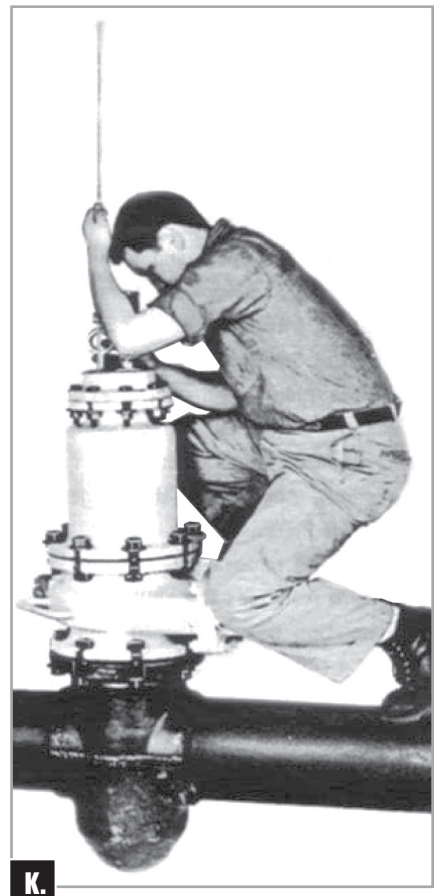

K.



Reliable Connections[®]

Gas (North America)
1.800.798.3131
www.muellergas.com
moreinfo@muellercompany.com

International
1.423.490.9555
www.mueller-international.com
international@muellercompany.com

Copyright © 2017 Mueller Co., LLC. All Rights Reserved.

The trademarks, logos and service marks displayed in this document herein are the property of Mueller Co., LLC, its affiliates or other third parties. Products marked with a section symbol (§) are subject to patents or patent applications. For details, visit www.mwppat.com. These products are intended for use in potable water applications. Please contact your Mueller Sales or Customer Service Representative concerning any other application(s).

Form 8834 – Rev 10/18