

# NO-BLO® Operations Using the E-5 or EH-5 Drilling Machine

TABLE OF CONTENTS	PAGE
Installing NO-BLO Service Tees, Valve Tees and Curb Valve Tees	5 - 14
Installing & Stopping-Off NO-BLO Service Tees, Valve Tees and Curb Valve Tees	15 - 16
Reconditioning Seat in NO-BLO Valve Tees and Curb Valve Tees	17
Reconditioning NO-BLO Steel Valves and Capped Steel Valves	18 - 19
Installing and Stopping-Off NO-BLO Service Line Stopper Fittings	20 - 27
Installing NO-BLO Save-A-Valve® Drilling Nipples	28 - 32

 **WARNING:**

1. Read and follow instructions carefully. Proper training and periodic review regarding the use of this equipment is essential to prevent possible serious injury and/or property damage. The instructions contained herein were developed for using this equipment on fittings of Mueller manufacturer only, and may not be applicable for any other use.
2. DO NOT exceed the pressure ratings of any components or equipment. Exceeding the rated pressure may result in serious injury and/or property damage.
3. Safety goggles and other appropriate protective gear should be used. Failure to do so could result in serious injury.
4. Pressure test, check for and repair leaks in all fittings and components each time one is installed or any joint or connection is broken. Failure to find and repair a leak from any source in the fittings, by-pass lines or equipment could result in an explosion and subsequent serious injury and/or property damage.
5. Mueller Drilling Machines and Equipment have been carefully designed and engineered to work together as a unit. The use of equipment manufactured by someone other than Mueller may cause excessive wear or a malfunction of the Mueller machines.

All warranties, expressed or implied, for Mueller Drilling Machines are rendered null and void if the machines are used with shell cutters or equipment manufactured by someone other than Mueller.

F 8545 11/21

# NO-BLO E-5 OR EH-5 DRILLING MACHINE

General Information

Use pipe thread sealant on the threads of machines or equipment if required to make a pressure tight threaded connection where a gasket or O-ring seal is not provided.

Examine rubber shut-off tools and replace rubbers if excessively worn or damaged. Lubricate the inside and all metal parts of rubber shut-off tool with a semi-liquid mixture of graphite and glycerin. When not in use, store rubber shut-off tools away from sunlight in a cool, damp location.

Keep all machined and threaded surfaces of machines and equipment well lubricated with oil at all times. DO NOT USE OIL TO LUBRICATE RUBBER SHUT-OFF TOOLS.

**⚠ WARNING: Before using this equipment, inspect the machine, control valve or chamber, adapters and the fittings that will be attached to the main or service line to verify that they are serviceable and able to contain the line and test pressures involved with the operation. Assure that all connecting threads and flanges, and all sealing gaskets and O-rings are in good condition, properly installed and capable of effecting a gas tight seal. DO NOT USE ANY PIECE OF EQUIPMENT IN QUESTIONABLE CONDITION.**

**After connecting all pieces of equipment on the fitting, but before subjecting the setup to line or test pressure, assure that all threaded or flanged connections are wrench tight and pressure test the setup using a suitable non-flammable gas introduced through an available Test Orifice (see following column). Repair any leakage found. Repeat this pressure test when any connection in the setup is disturbed. DO NOT ALLOW LINE OR TEST PRESSURE INTO THE SETUP IF ANY LEAKAGE CANNOT BE STOPPED.**

**Failure to comply with this warning could result in fire or explosion, and the possibility for property damage, serious bodily harm, injury or even death.**

## Test Orifice locations:

**E-5 or D-5 Machine — Test Plug just above threads at bottom of Machine.**

**EH-5 or DH-5 Machine — Blow Off Valve at bottom of machine (remove valve to introduce pressure then replace and close Blow Off Valve before using machine).**

**Control Chamber or Slide Gate Valve — Test Plug on Bypass Valve (place valve in bypass position when pressure testing).**

Before using this equipment, read and understand the important General Instructions on the preceding sections of this page (page 2). Failure to read, understand and follow these instructions could result in unsafe operation of the equipment, damage to equipment or system components, or even severe bodily harm.

The E-5 and EH-5 Drilling Machine Equipment shown on this page is for use with Mueller® NO-BLO Tees, NO-BLO Valves, NO-BLO Service Line Stopper Fittings and NO-BLO Save-A-Valve Drilling Nipples. Refer to the Mueller Gas Distribution Products Catalog to select the necessary equipment for the specific operation to be performed.

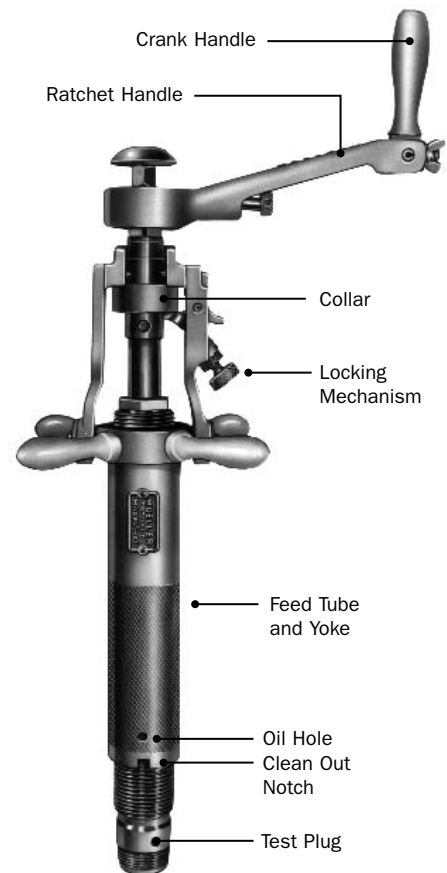

E-5 Machine



EH-5 Machine

# NO-BLO E-5 OR EH-5 DRILLING MACHINE

Installing NO-BLO Service Tees, Valve Tees and Curb Valve Tees

These instructions are for doing the following NO-BLO operations using the E-5 Drilling Machine or the EH-5 Drilling Machine.\* Also see specific Operating Instructions for each of these machines.

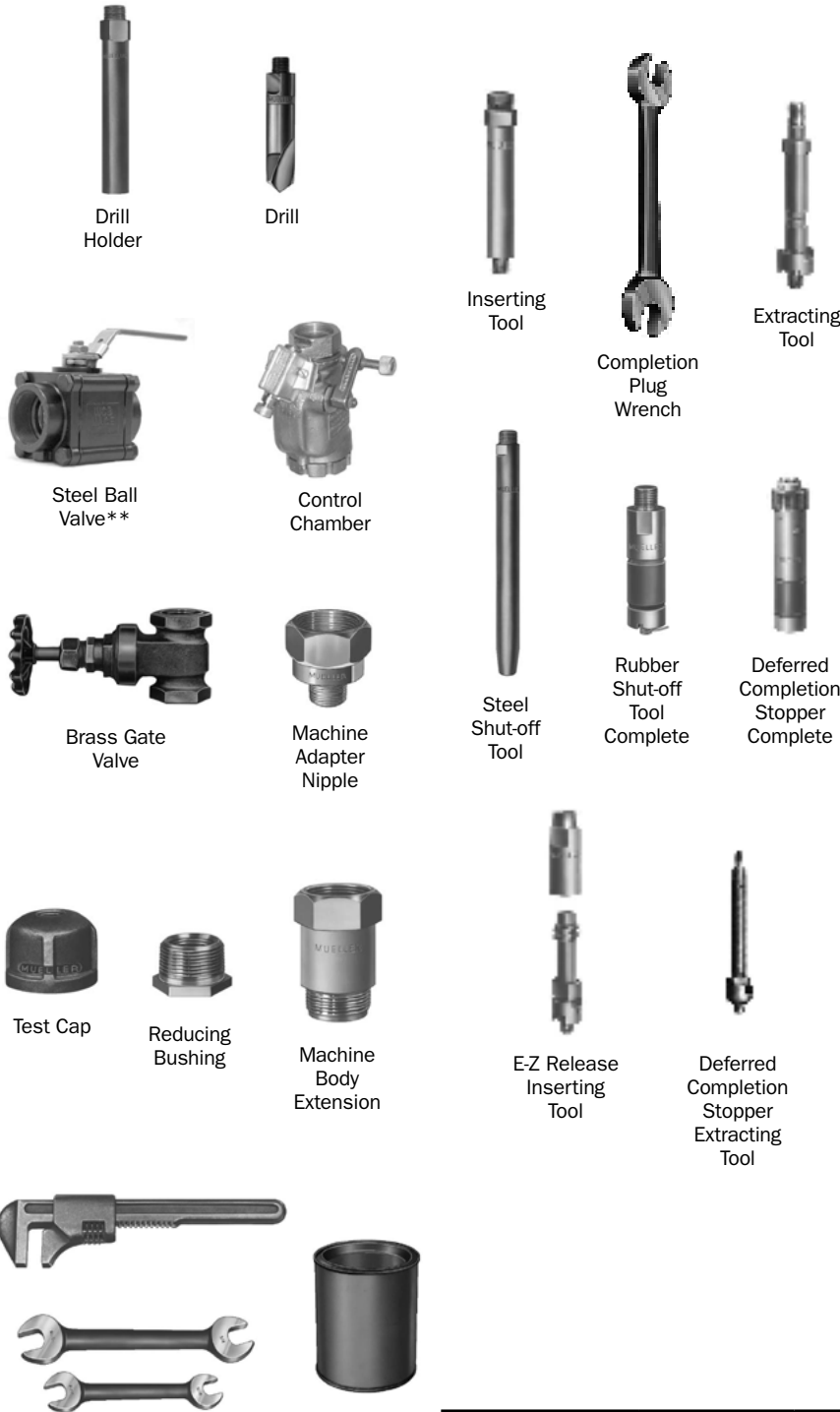

ITEM	SIZE OF INLET	NO-BLO OPERATIONS
NO-BLO Tees	¾", 1", 1¼", 1½", 2"	Drill the Main Insert the Plug Extract the Plug Make Stop-Off
NO-BLO Valve Tees Bushing	¾", 1", 1¼"	Drill the Main Insert Stem & Bushing Extract Stem and Recondition Body Seat
NO-BLO Curb Valve Tees	¾", 1", 1¼"	Drill the Main Insert the Stem Extract the Stem Recondition Body Seat

Rubber shut-off tools have a maximum working pressure of 500 psig. Except for rubber shut-off tools, the following table lists the maximum working pressure of the machine and its equipment. During the use of this equipment, the line pressure must not exceed the amount indicated.

\*The EH-5 Drilling Machine is a high pressure machine having balanced pressure design. The line pressure is equalized within the machine, permitting the boring bar and tool to be easily advanced or easily retracted. It is never necessary to operate this machine against the full effective force of the line pressure. The EH-5 Drilling Machine uses E-5 Drilling Machine tools and equipment.

CATALOG NO. OF DRILLING MACHINE	TYPE OF VALVE TO BE USED	MAXIMUM WORKING PRESSURE	MAXIMUM TEMPERATURE RATING
E-5	H-10914 H-10918** H-17025	125 psig at 100° F 500 psig at 100° F 125 psig at 100° F	250° F at 100 psig 250° F at 375 psig 250° F at 100 psig
EH-5	H-10914 H-10918** H-17024	125 psig at 100° F 1200 psig at 100° F 125 psig at 100° F	250° F at 100 psig 250° F at 1140 psig 250° F at 100 psig

\*\* The H-10918 Steel Ball Valve has replaced the H-10916 Steel Gate Valve (not shown) — refer to the Mueller Gas Products Catalog for the correct tools to use with the H-10918 control valve.

# NO-BLO E-5 OR FH-5 DRILLING MACHINE

Installing NO-BLO Service Tees, Valve Tees and Curb Valve Tees

## A. SELECT THE NO-BLO EQUIPMENT REQUIRED

1. Determine the catalog number of the control valve or control chamber to be used. See table on preceding column and FIGURE 1.



2. Refer to the Gas Distribution Products Catalog to select the proper E-5 Machine tools and equipment according to the following:

- Size and catalog number of the NO-BLO Tee to be installed.
- Catalog number of the control valve or control chamber to be used. Options are listed in the Gas Distribution Products Catalog with the ordering information for the fitting.

3. Select the drilling tools to be used. The maximum size of drilling tools which can be used is listed with the fitting information in the Gas Distribution Products Catalog.

4. Select the other tools and equipment needed by referring to the chart in the Gas Distribution Products Catalog that accompanies the selected valve or control chamber.

## B. ATTACH THE NO-BLO TEE TO THE MAIN

1. Thoroughly clean the surface to

which the Tee is to be attached.

2. For Service, Valve and Curb Valve Tees:

- Service Tees — Remove completion cap and completion plug. FIGURE 2.



- Valve Tees — Remove completion cap and stem & bushing as a unit. FIGURE 3.



- Curb Valve Tees — Remove Tee handle, cap and stem. FIGURE 4.



3. For Tees having a welding or outside I.P. thread inlet:

- Tees having welding inlet — Place Tee in desired position and weld to pipe line. FIGURE 5.



- Tees having an outside I.P. thread inlet — Attach Service Clamp at the desired position. Apply non-hardening pipe thread sealant to the inlet threads of the Tee, and screw it tightly into the body of the Service Clamp. FIGURE 6.



**NOTE: When using a Tee having a threaded inlet, it may be necessary to reduce the working pressure and temperature of the clamp or fitting to which the Tee is attached.**

4. Connect service pipe to the outlet of the Tee and extend this piping to the first shut-off in the service line, such as a curb valve or meter valve. Close this curb valve or meter valve.

5. If installing a  $\frac{3}{4}$ ", 1" or  $1\frac{1}{4}$ " NO-BLO Service Tee or Valve Tee, the H-17615 Center Locating Punch may be used to punch mark the pipe in the center of the Tee to aid in starting the drill. Screw the Center Locating Punch into the Tee and strike the head of the pin with a solid blow. FIGURE 7.

# NO-BLO E-5 OR EH-5 DRILLING MACHINE

Installing NO-BLO Service Tees, Valve Tees and Curb Valve Tees



7.

## C. TEST THE INSTALLATION

1. Screw test cap on NO-BLO Tee.
2. Apply air pressure and test for leaks with soapsuds (add glycerin in freezing weather) or a leak detection fluid. FIGURE 8.
3. Remove test cap.



8.

## D. ATTACH CONTROL VALVE OR CONTROL CHAMBER

1. If using a control valve:
  - a) Attach valve to top of NO-BLO Tee, FIGURE 9. (If installing a 3/4" Service Tee, first attach the

1 3/4" x 1" bushing to the Tee then attach the valve to the bushing.

- b) Open valve fully.



9.

2. If using a Control Chamber:

- a) Assemble proper size adapter bushing to the lower thread of the control chamber. Be sure the O-ring is in place, lubricated and in good condition. Spanner wrench part no. 44628 may be used for assembling this bushing.
- b) Secure the bushing in place with the set screw.
- c) Attach control chamber to top of NO-BLO Tee.
- d) Loosen handle screw and open valve gate fully.
- e) PULL bypass valve to the bypassing position (twist to lock). FIGURE 10.



10.

## E. ATTACH DRILLING MACHINE

1. Attach machine adapter nipple or machine body extension to the body of the machine. Be sure the gasket is in good condition and in place. A machine adapter nipple is always required if using a valve. A machine body extension is only required with the control chamber when it is a listed item in the tools and equipment charts provided in the Catalog.

2. Assemble proper size drill and drill holder (combined drill and holder or shell cutter and holder) to the boring bar of the machine.

3. Coat drill thoroughly with Mueller Cutting Grease. FIGURE 11.



11.

4. Retract boring bar to its rear most position.

5. If using a control valve, place the drilling machine on the control valve and tighten machine adapter nipple into control valve. FIGURE 12. (Close bleeder valve on EH-1 Machine.)



12.

# NO-BLO E-5 OR EH-5 DRILLING MACHINE

Installing NO-BLO Service Tees, Valve Tees and Curb Valve Tees

6. If using a control chamber, place the drilling machine on the control chamber and tighten the body of the machine directly into the top of the control chamber. Be sure O-ring is in place, lubricated and in good condition. FIGURE 13.



## F. DRILL THE MAIN

1. Slowly advance boring bar until point of drill contacts the pipe. Then retract boring bar a slight amount.
2. Adjust feed tube and yoke so that the yoke engages the collar on boring bar. Tighten locking mechanism against underside of collar.
3. Drill the hole by operating the ratchet handle clockwise and turning the feed tube and yoke clockwise, a little at a time, FIGURE 14.



Use a light, even feed at the start, then a heavier feed and finish with a light, even feed. To prevent over-feeding when drilling small holes and also when starting to drill larger holes, apply the feed by gripping the knurled section of the feed tube instead of the feed handles. E-5 and EH-5 Machines are furnished with a combination ratchet and crank handle. When drilling small holes, the crank handle should be turned upward and rotated in continuous circles instead of ratcheting.

4. Continue drilling until a hole is drilled in the pipe. This can be determined by the feeling of the feeding mechanism and the pull of the ratchet handle.

## G. REMOVE THE DRILLING MACHINE

1. When the drilling operation is completed, retract the boring bar to its rearmost position. Be sure the point of the drill is above the valve gate of either the valve or the control chamber.

**⚠ CAUTION: DO NOT REVERSE THE ROTATION OF THE RATCHET HANDLE WHEN RETRACTING THE BORING BAR — PRESSURE INSIDE THE E-5 DRILLING MACHINE WILL TEND TO RAISE THE BORING BAR FORCEFULLY — KEEP FACE AND BODY CLEAR OF TOP OF BORING BAR AND RATCHET HANDLE. USE THE FEED YOKE TO CONTROL THE UPWARD MOTION OF THE BORING BAR, THEREBY PREVENTING SHOCK OR DAMAGE TO THE DRILLING MACHINE, OR BODILY INJURY.**

2. If using valve, close it. (Open bleeder valve on EH-5 Machine.)
3. If using a control chamber:
  - a) Close the valve gate and secure in the closed position by tightening handle screw hand tight against the wrench flats of the control chamber.
  - b) Push bypass valve to the relieving position. This will release the pressure from above the valve

gate, and also indicate whether or not the valve gate is seated tightly.

4. Remove drilling machine from valve or control chamber.
5. Advance boring bar.
6. Remove drilling tools.

## H. INSERT PLUG, STEM AND BUSHING OR STEM

1. Assemble plug inserting tool to the right hand threads in the end of the boring bar of drilling machine.
2. For No-Blo Service, Valve & Curb Valve Tees:
  - a) Service Tees — Attach the completion plug to the plug inserting tool. Lubricate these threads and be sure that the threads screw together freely without binding. Apply non-hardening pipe thread sealant to the completion plug threads. FIGURE 15.



- b) Valve Tees — Unscrew stem approximately half way out of the bushing, then attach the bushing to the plug inserting tool. Lubricate these threads and be sure that the threads screw together freely without binding. Screw stem into bushing as far as possible by hand, then back it out one-half of a turn. FIGURE 16.



- c) Curb Valve Tees — Curb Valve Tees use an E-Z Release type inserting tool. Lubricate the acme threads between the two parts of

# NO-BLO E-5 OR EH-5 DRILLING MACHINE

Installing NO-BLO Service Tees, Valve Tees and Curb Valve Tees

this tool and be sure they screw together freely without binding. Screw the end of the tool into the end of the stem and secure in place by lowering the fork over the squared section of the stem. FIGURE 17.



17.

**3.** Retract boring bar to its rearmost position.

**4.** Reattach drilling machine to valve or control chamber. Machine will be under pressure as next steps are completed. Keep face and body clear of upper end of E-5 machine, boring bar and ratchet handle.

**5.** If using a valve, open it fully.

**6.** If using a control chamber:

- a) Pull bypass valve to the bypassing position (twist to lock).
- b) Loosen handle screw and open the valve gate fully.

**7.** Advance boring bar until the completion plug, bushing or stem (Curb Valve Tee) contacts the top thread in the Tee. Hold the boring bar down against pressure with the feed yoke, if desired.

**8.** Rotate the ratchet handle clockwise until the completion plug, bushing or stem (Curb Valve Tee) is firmly screwed into the Tee.

**9.** Reverse ratchet and turn the ratchet handle counter-clockwise to take up the slack. Hold in this position with one hand and strike the end of the ratchet handle with a sharp blow counter-clockwise with the other hand. FIGURE 18.



18.

**10.** Rotate the boring bar counter-clockwise until the inserting tool is free from the completion plug or bushing. If installing a Curb Valve Tee, the upper part of the E-Z Release inserting tool will unscrew from the lower part.

**11.** If using control chamber, push the bypass valve to the relieving position. If there is full flow from the bypass valve at this point, rotate the ratchet handle clockwise and seat the completion plug, bushing or stem more tightly. (If using valve and EH-5 Machine, open bleeder valve.)

**12.** Remove drilling machine, valve or control chamber.

**13.** For Service, Valve & Curb Valve Tees:

a) Service Tees, FIGURE 19.



19.

(1) Tighten completion plug with

completion plug wrench.

(2) Apply non-hardening pipe thread sealant to completion cap threads and screw cap tightly on Tee.

b) For Valve Tees, FIGURE 20.



20.

(1) Tighten bushing with completion plug wrench.

(2) With screw driver, turn stem counter-clockwise to back seat against the bottom of the bushing.

(3) Apply non-hardening pipe thread sealant to completion cap threads and screw cap firmly on Tee.

c) For Curb Valve Tee, FIGURE 21.



21.

# NO-BLO E-5 OR FH-5 DRILLING MACHINE

Installing NO-BLO Service Tees, Valve Tees and Curb Valve Tees

- (1) Lubricate both O-rings and tighten cap firmly on Tee.
- (2) Replace Tee handle.
- (3) Open the valve by turning Tee handle counter-clockwise.

**14.** Test the entire Tee with soapsuds (add glycerin in freezing weather) or a leak detection fluid.

## I. TO OPERATE A NO-BLO VALVE TEE

- 1.** Remove completion cap.
- 2.** Screw stem into Tee as far as possible using a 4" screw driver.
- 3.** Polish the seat by turning the stem back and forth several times against the seat.
- 4.** Hold the stem in the closed position with the screw driver in one hand and BACK OFF the bronze bushing with a wrench held in the other hand. (Do not permit the stem to turn; however, turn the bushing approximately two full turns counter-clockwise). Differential threads provide the seating force. FIGURE 22.



**5.** The Valve Tee is now shut off. Proceed with the work on the service line.

**6.** To open the valve hold the stem in the closed position with the screw driver in one hand, and tighten the bushing into the Tee with a wrench held in the other hand. (Do not

permit the stem to turn; however, turn the bushing as far as it will go clockwise). This relieves the force created by the differential threads.

**7.** Open valve by rotating the stem counter-clockwise with the screw driver. Continue rotating in this direction until the stem backseats against the bottom of the bushing.

**8.** Apply non-hardening pipe thread sealant to the completion cap threads and screw cap tightly on Tee.

**9.** Test the entire Tee with soapsuds (add glycerin in freezing weather) or a leaked detection fluid.

## J. TO REMOVE COMPLETION PLUG, STEM AND BUSHING OR STEM (NO-BLO CURB VALVE TEE)

If using a control chamber, place the drilling machine on the control chamber and tighten the body of the machine directly into the top of the control chamber. Be sure O-ring is in place, lubricated and in good condition.

**1.** For NO-BLO Service, Valve and Curb Valve Tees:

- a) Service Tees — Remove completion cap and loosen completion plug slightly with the completion plug wrench.
- b) Valve Tees — Remove completion cap, close valve approximately halfway and loosen bushing slightly with completion wrench.
- c) Curb Valve Tees — Close valve tightly, remove Tee handle and remove cap.

**2.** Attach extracting tool to completion plug, bushing or stem (Curb Valve Tee). FIGURE 23.



a) Move the fork away from the threads on the end of the tool.

b) Screw the end of the tool into the threads in the top of the completion plug, bushing or stem.

c) Slide the fork downward so that it bears against the flats on the completion plug, bushing or stem.

**3.** Fully open valve or control chamber.

**4.** Attach valve or control chamber. See instruction D, page 5.

**5.** If using control chamber, pull bypass valve to the bypassing position (twist to lock).

**6.** Attach machine adapter nipple or body extension to the drilling machine. See instruction E-5, page 5.

**7.** If using a valve, place the drilling machine on the valve and tighten machine adapter nipple into valve.

**8.** If using a control chamber, place the drilling machine on the control chamber and tighten the body of the machine directly into the top of the control chamber. Be sure O-ring is in place, lubricated and in good condition.

**9.** Lower the boring bar of the



# NO-BLO E-5 OR EH-5 DRILLING MACHINE

Installing NO-BLO Service Tees, Valve Tees and Curb Valve Tees

drilling machine until it contacts the top of the extracting tool.

**10.** Rotate the boring bar counter-clockwise. The boring bar will first engage the left hand threads on top of the extracting tool. When these threads are fully engaged continue rotating in a counter-clockwise direction which will unscrew the plug, bushing or stem from the Tee.

**11.** Retract boring bar to its rearmost position.

**⚠ CAUTION: THE PRESSURE INSIDE THE E-5 MACHINE WILL TEND TO RAISE THE BORING BAR. KEEP FACE AND BODY CLEAR OF UPPER END OF BORING BAR AND RATCHET HANDLE. USE THE FEED YOKE TO CONTROL THE UPWARD MOTION OF THE BORING BAR THEREBY PREVENTING SHOCK OR DAMAGE TO THE DRILLING MACHINE OR BODILY INJURY.**

**12.** Close valve or control chamber. See instruction G-3, page 6. (Open bleeder valve on EH-5 Machine.)

**13.** If using control chamber, push bypass valve to the relieving position.

**14.** Remove drilling machine from valve or control chamber.

**15.** Advance boring bar. FIGURE 24.



**16.** Remove extracting tool from the boring bar.

**NOTE: Left hand threads between the extracting tool and the boring bar.**

**17.** Remove the completion plug, bushing or stem (Curb Valve Tee) from the extracting tool.

## K. TO STOP-OFF NO-BLO SERVICE TEE

A rubber shut-off tool is used to provide a positive shut-off in a service line at the No-Blo Tee. It should not be used for repair welding on either the inlet or outlet connections of the Tee. (To use a Deferred Completion Stopper to stop-off threaded inlet Service Tees, see NOTE on page 15.)

A steel shut-off tool is used to provide a temporary shut-off in a service line at the Tee when repair welding on either the inlet or outlet connections of the Tee.

**1.** Assemble shut-off tool to the boring bar of the drilling machine.

a) A rubber shut-off tool uses a drill holder between it and the boring bar. Lubricate the rubber with Mueller Rubber Stopper Lubricant (Part no. 580657).

b) A steel shut-off tool attaches directly to the end of the boring bar. FIGURE 25.



**2.** Retract boring bar to its rearmost position.

**3.** Attach the drilling machine to the control valve or control chamber. Machine will be under pressure as the following steps are completed—keep face and body clear of upper end of E-5 Machine, boring bar and ratchet handle.

**4.** If using a control valve, place the drilling machine on control valve and tighten machine adapter nipple into control valve.

**5.** If using a control chamber, place the drilling machine on the control chamber and tighten the body of the machine directly into the top of the control chamber. Be sure O-ring is in place, lubricated and in good

condition. Pull bypass valve to the bypass position (twist to lock).

**6.** Open control valve or control chamber fully.

**7.** Advance boring bar.

a) If using a Service Tee with welding inlet, advance boring bar until the lower end of the shut-off tool contacts the pipe. FIGURE 26.



b) If using a Service Tee with Outside I.P. thread-on inlet, advance boring bar until the lower end of the shut-off tool contacts a ledge or shoulder on the inside and at the bottom of the Tee.

A machined groove around the body of the Tee just before the completion cap indicates that the threaded inlet Tee has the ledge on the inside, FIGURE 27. Previous design - threaded inlet Tees did not have the ledge or the identifying groove, and require special tools - contact Mueller Gas Division Customer Service.



**7.** Adjust the feed tube and yoke so that the yoke engages the collar on the boring bar. Tighten locking mechanism against underside of collar.

**8.** Turn feed yoke handles clockwise until the shut-off tool effectively shuts off the pressure. The boring bar should not be rotated during

# NO-BLO E-5 OR EH-5 DRILLING MACHINE

Reconditioning Seat In NO-BLO Valve Tees and Curb Valve Tees

this operation.

**9.** If using control chamber, push bypass valve to relieving position. This will blow down the service fine and also test the effectiveness of the shut-off. (If using the valve and EH-5 Machine, open bleeder valve.)

**10.** Once assured of a full stop off, proceed with the work on the service line.

**11.** When the work on the service fine is completed, if using a control chamber, pull bypass valve to the bypassing position (twist to lock).

(Close bleeder valve on EH-5 Machine.)

**12.** Turn feed yoke handles counter-clockwise relaxing the downward force on the shut-off tool. E-5 Machine will be under pressure - keep face and body clear of upper end of E-5 Machine, boring bar and ratchet handle while performing the following steps.

**13.** Disengage the feed yoke and retract boring bar to its rearmost position. Control upward motion of boring bar on E-5 Machine.

**14.** Close control valve or control chamber. (Open bleeder valve on EH-5 Machine.)

**15.** If using a control chamber, push bypass valve to relieving position.

**16.** Remove drilling machine from control valve or control chamber.

**17.** Advance boring bar and remove shut-off tool.

**18.** Insert completion plug, bushing or stem (Curb Valve Tee). See instruction H, page 6.

## L. TO RECONDITION BODY SEAT IN NO-BLO VALVE TEE OR CURB VALVE TEE

**1.** Remove stem and bushing from Valve Tee or stem from Curb Valve Tee. See instruction J, page 8.

**2.** Attach drill holder to boring bar of drilling machine.

**3.** Attach reseating reamer to drill holder. FIGURE 28.



SIZE OF TEE	1"	1¼"
Reseating Reamer – Part Number	72240	72241
Drill Holder – Part Number	61981	78736

**4.** Retract boring bar to its rearmost position.

**5.** Attach the drilling machine to control valve or control chamber. E-5 Machine will be under pressure - keep face and body clear of upper end of E-5 Machine, boring bar and ratchet handle while performing the following steps.

**6.** If using control chamber, pull bypass valve to the bypassing position (twist to lock).

**7.** Open control valve or control chamber fully.

**8.** Advance boring bar until the reamer contacts the body seat.

**9.** Adjust the feed tube and yoke so that the yoke engages the collar on the boring bar. Tighten locking mechanism against underside of collar.

**10.** Turn the crank handle upward. FIGURE 29.



**11.** Rotate the boring bar clockwise in continuous circles, and at the same time, apply 3 very light feed by turning the feed handle clockwise a very small amount.

**12.** When the reaming operation is completed, disengage the feed yoke, and retract boring bar to its rearmost position. Machine will be under pressure - control upward movement of E-5 Machine, boring bar - keep face and body clear of upper end of boring bar and ratchet handle.

**13.** Close control valve or control chamber (Open bleeder valve on EH-5 Machine.)

**14.** If using a control chamber, push bypass valve to relieving position.

**15.** Remove drilling machine from control valve or control chamber.

**16.** Advance boring bar and remove reamer and drill holder.

**17.** Insert bushing or stem (Curb Valve Tee). See Instruction H, page 6.

These instructions are for doing the following NO-BLO operations using the E-5 Drilling Machine or the EH-5 Drilling Machine\*. Also see specific Operating Instructions for each of these drilling machines.

ITEM	SIZES	NO-BLO OPERATIONS
NO-BLO Steel Valves	¾", 1"	Insert Stem Extract Stem Recondition Body Seat
NO-BLO Capped Steel Valves	¾", 1"	Insert Stem & Bushing Extract Stem & Bushing Recondition Body Seat

During the reconditioning operations the pressure and temperature must not exceed the amounts indicated in the table at the top of the next page.

29.

# NO-BLO E-5 OR EH-5 DRILLING MACHINE

Reconditioning Seat In NO-BLO Valve Tees and Curb Valve Tees

CATALOG NO. OF DRILLING MACHINE	TYPE OF VALVE TO BE USED	MAXIMUM WORKING PRESSURE	MAXIMUM TEMPERATURE RATING
E-5	H-10914	125 psig at 100° F	250° F at 100 psig
	H-10918	500 psig at 100° F	250° F at 375 psig
	H-17025	125 psig at 100° F	250° F at 100 psig
EH-5	H-10914	125 psig at 100° F	250° F at 100 psig
	H-10918	1200 psig at 100° F	250° F at 1140 psig
	H-17024	125 psig at 100° F	250° F at 100 psig

The reconditioning of a NO-BLO Steel Valve is the same as corresponding operations for a Curb Valve Tee and uses the same equipment. FIGURE 30.



The reconditioning of a NO-BLO Capped Steel Valve is the same as corresponding operations for a Valve Tee and uses the same equipment. FIGURE 31.



\*The EH-5 Drilling Machine is a high pressure machine having balanced pressure design. The line pressure is equalized within the machine, permitting the boring bar and tool

to be easily advanced or easily retracted. It is never necessary to operate this machine against the full effective force of the line pressure. The EH-5 Drilling Machine uses E-5 Drilling Machine tools and equipment.

## A. SELECT THE NO-BLO EQUIPMENT REQUIRED

**1.** Determine the catalog number of the control valve to be used with the E-5 or EH-5 Drilling Machine. See page 4, FIGURE 1.

**2.** Select the proper E-5 Machine tools and equipment according to the following:

- Size and catalog number of the NO-BLO Steel Valve or NO-BLO Capped Steel Valve that is to be reconditioned.
- The catalog number of the valve to be used with the E-5 or EH-5 Machine (H-10914, H-10918 or H-17025).

The required tools and equipment are listed in the Gas Distribution Products Catalog.

**3.** Select the size of the valve to be used (H-10914, H-10918) or the size of the bushing to be used with the control chamber. This is listed in the Catalog in the same column as the control valve or control chamber.

**4.** Select the reseating reamer and drill holder from the following table:

SIZE OF NO-BLO VALVE	¾" AND 1"
Reseating Reamer - Part Number	72240
Drill Holder - Part Number	61981

## B. REMOVE STEM OR STEM AND BUSHING

**1.** NO-BLO Steel Valves and NO-BLO Capped Steel Valves:

a) Steel Valves- Close the valve tightly. Remove tee handle and remove cap. Remove the stem by following instruction J, page 8 for removing the stem from the Curb Valve Tee.

b) Capped Steel Valves - Remove completion cap, close valve approximately half way and loosen bushing slightly with completion wrench. Remove the bushing (Including the stem) by following instruction J, page 8 for removing the bushing from a Valve Tee.

## C. RECONDITION THE VALVE

**1.** Recondition the body seat. See instruction L, page 10.

**2.** Replace worn or damaged parts. Every part can be replaced except the body.

**3.** Lubricate all O-rings

## D. INSERT STEM OR BUSHING

**1.** For NO-BLO Steel Valves and NO-BLO Capped Steel Valves:

a) Steel Valves- Follow instruction H, page 6 for Inserting stem Into Curb Valve Tee. Replace cap and tee handle.

b) Capped Steel Valves - Follow instruction H, page 6 for Inserting bushing Into Valve Tee. Open or close valve as required and replace completion cap.

## E. TO OPERATE NO-BLO CAPPED STEEL VALVES

**1.** Follow instruction I, page 8.

## F. MAINTENANCE VALVE

(CHANGE O-RINGS AND CAP)

**1.** This can be done under pressure.

**2.** Thread the stem all the way down.

**3.** Remove Operating Head and Completion Cap.

# NO-BLO E-5 OR EH-5 DRILLING MACHINE

Reconditioning Seat In NO-BLO Valve Tees and Curb Valve Tees

4. Service valve as needed.
5. Replace Operating Head and Completion Cap.

These instructions are for doing the following NO-BLO operations using the E-5 or EH-5 Drilling Machine. Also see "OPERATING INSTRUCTIONS FOR THE MUELLER E-5 DRILLING MACHINE."

ITEM	SIZES	NO-BLO OPERATIONS
NO-BLO Service Line Stopper Fitting	¾", 1", 1 ¼"	Drill the Service Line Insert Plug Extract Plug Make Stop-Off

NO-BLO Rubber shut-off tools have a maximum working pressure of 100 psig. Except for rubber shut-off tools, the following table lists the maximum working pressure of the machine or its equipment. During the use of this equipment, the line pressure must not exceed the amounts indicated.

## A. SELECT THE NO-BLO EQUIPMENT REQUIRED

1. Determine the catalog number of the control valve to be used. See table below and FIGURE 1.
2. Select the proper E-5 Machine tools and equipment according to the following:
  - a) Size and catalog number of the NO-BLO Service Line Stopper Fitting to be installed.
  - b) Catalog number of the control valve to be used. The required tools and equipment are listed in the Gas Distribution Products Catalog.
3. Select the drilling tools to be used. The proper size is listed in the Gas Distribution Products Catalog.

CATALOG NO. OF DRILLING MACHINE	TYPE OF VALVE TO BE USED	MAXIMUM WORKING PRESSURE	MAXIMUM TEMPERATURE RATING
E-5 or EH-5	H-10914	125 psig at 100° F	250° F at 100 psig
	H-10918	1200 psig at 100° F	250° F at 1140 psig
	H-17025	125 psig at 100° F	250° F at 100 psig

4. Select the proper size of the control valve or proper size of the control chamber bushing. This is listed in the catalog in the same column as the control valve or control chamber.

## B. ATTACH THE NO-BLO FITTING TO THE SERVICE LINE

1. Thoroughly clean the surface to which the fitting is to be attached.
2. Remove completion cap and completion plug. FIGURE 32.



3. Loosely reassemble completion cap to top half, and place the two halves of the fitting around the pipe with the trade mark on each half facing in the same direction, and in accurate alignment with each other.
4. Tack weld the four corners.
5. Weld the two halves of the fitting together but free of the pipe.
6. Locate the fitting in the desired position and weld each end permanently to the pipe. FIGURE 33.



7. Remove completion cap.

## C. TEST THE INSTALLATION

1. Screw test cap on fitting.
2. Apply air pressure and test for leaks with soapsuds (add glycerin in freezing weather) or bubble-type leak detection fluid. FIGURE 34.



3. Remove test cap.
4. If desired, H-17615 Center Locating Punch may be used with NO-BLO Service Line Stopper Fittings to punch mark the pipe to aid in starting the drill. See instruction B-5, page 4.

## D. ATTACH VALVE OR CONTROL CHAMBER

1. If using a control valve:
  - a) Attach control valve to top of fitting. FIGURE 35.

# NO-BLO E-5 OR EH-5 DRILLING MACHINE

Installing & Stopping-off NO-BLO Service Line Stopper Fittings



- b) Open control valve fully.
- 2.** If using a control chamber:
- a) Assemble proper size adapter bushing to the lower thread of the control chamber. Be sure the O-ring is in place, lubricated and in good condition. Spanner wrench (part no. 44628) may be used for assembling this bushing.
- b) Secure the bushing in place with the set screw.
- c) Attach control chamber to top of fitting. FIGURE 36.



- d) Loosen handle screw and open valve gate fully.
- e) Pull bypass valve to the bypassing position (twist to lock).

## E. ATTACH DRILLING MACHINE

- 1.** If using a control valve, attach machine adapter nipple to the body of machine. Be sure the gasket is in good condition and in place. A machine adapter nipple is always required if using a control valve.
- 2.** Assemble proper size drill and drill holder to the boring bar of the machine.
- 3.** Coat drill thoroughly with Mueller Cutting Grease. FIGURE 37.



- 4.** Retract bar to its rearmost position.
- 5.** If using a control valve, place the drilling machine on control valve and tighten machine adapter nipple into control valve. FIGURE 38.



- a) Remove bleeder valve of EH-5 machine. Attach air line, apply air pressure and check for leaks.
- b) Remove air line and replace bleeder valve. Be sure bleeder valve is closed.

- 6.** If using a control chamber, place the drilling machine on the control chamber and tighten the body of the machine directly into the top of the control chamber. Be sure the O-ring

is in place, lubricated and in good condition. FIGURE 39.



## F. DRILL THE SERVICE LINE

- 1.** Slowly advance boring bar until point of drill contacts the pipe. Then, retract boring bar a slight amount.
- 2.** Adjust feed tube and yoke so that the yoke engages the collar on boring bar. Tighten locking mechanism against underside of collar.
- 3.** Measure and mark the travel required to complete the cut as shown in the following table:

NECESSARY TRAVEL TO COMPLETE CUT	
SIZE AND KIND OF PIPE	FROM POINT OF DRILL CONTACT ON PIPE
3/4" Steel	19/16" "
1" Steel	1 13/16" "
1 1/4" Steel	2 1/4" "

- 4.** Drill the hole by operating the ratchet handle clockwise, and turning the feed tube and yoke clockwise, a little at a time. FIGURE 40.



# NO-BLO E-5 OR FH-5 DRILLING MACHINE

## Installing & Stopping-off NO-BLO Service Line Stopper Fittings

Use a light, even feed at the start, then a heavier feed, and finish with a light, even feed. To prevent over-feeding when drilling small holes and also when starting to drill larger holes, apply the feed by gripping the knurled section of the feed tube instead of the feed handles.

5. Continue drilling until the pipe is drilled completely through. This can be determined by feel of the feeding mechanism, the pull on the ratchet handle, or by the measured travel of the boring bar.

### G. REMOVE THE DRILLING MACHINE

1. When the drilling operation is completed, retract the boring bar to its rearmost position. Be sure the point of the drill is above the valve gate of either the valve or the control chamber.

**⚠ CAUTION: DO NOT REVERSE THE ROTATION OF THE RATCHET HANDLE WHEN RETRACTING THE BORING BAR - PRESSURE INSIDE THE E-5 MACHINE WILL TEND TO RAISE THE BORING BAR FORCEFULLY - KEEP FACE AND BODY CLEAR OF UPPER END OF BORING BAR AND RATCHET HANDLE. USE THE FEED YOKE TO CONTROL THE UPWARD MOTION OF THE BORING BAR, THEREBY PREVENTING SHOCK OR DAMAGE TO THE DRILLING MACHINE, OR BODILY INJURY.**

2. If using a control valve, close it.

3. If using control chamber:

a) Close the valve gate and secure it in the closed position by tightening the handle screw hand tight against the wrench flats of the control chamber.

b) Push by-pass valve to the relieving position. This will release the pressure from above the valve gate and also indicate whether or not the valve gate is seated tightly.

4. Remove drilling machine from valve or control chamber.

5. Advance boring bar.

6. Remove drilling tools.

### H. STOP OFF THE NO-BLO FITTING

1. Attach proper drill holder to boring bar of drilling machine.

2. Attach rubber NO-BLO shut-off tool to the drill holder. Lubricate the rubber with Mueller Rubber Stopper Lubricant (Part no. 580657).

3. Retract boring bar to its rearmost position.

4. Reattach the drilling machine to the valve or control chamber pressure tight. In the next steps, machine will be under pressure - control upward movement of E-5 Machine boring bar - keep face and body clear of upper end of boring bar and ratchet handle.

5. If using control valve, open it fully.

6. If using a control chamber:

a) Pull bypass to the bypassing position (twist to lock).

b) Loosen handle screw and open valve gate fully.

7. Advance boring bar until the lower end of the shut-off tool contacts the bottom of the fitting.

8. Adjust the feed tube and yoke so that the yoke engages the collar on boring bar. Tighten locking mechanism against underside of collar.

9. Turn feed yoke handles of drilling machine clockwise, a little at a time, with a short pause after each turn. Continue to compress the shut-off tool in this manner until the line is stopped off. FIGURE 41.



Boring bar should not be rotated during this operation. The maximum amount of downward travel of the

boring bar is shown below.

¾" Fitting	¾" Downward Travel
1" Fitting	1 ⅛" Downward Travel
1 ¼" Fitting	1 ½" Downward Travel

10. Proceed with the work on the service line.

### I. RETRACT SHUT-OFF TOOL FROM FITTING

1. When all desired work has been done on the stopped off section of the service line, contract the shut-off tool by turning feed handles counter-clockwise, a little at a time, with a short pause after each turn. Continue to contract the shut-off tool in this manner until it is fully released.

2. Retract boring bar to its rearmost position.

**⚠ CAUTION: THE PRESSURE INSIDE THE E-5 MACHINE WILL TEND TO RAISE THE BORING BAR. USE THE FEED YOKE TO CONTROL THE UPWARD MOTION OF THE BORING BAR - KEEP FACE AND BODY CLEAR OF UPPER END OF BORING BAR AND RATCHET HANDLE, THEREBY PREVENTING SHOCK OR DAMAGE TO THE MACHINE, OR BODILY INJURY.**

3. Close control valve or control chamber. See instructions G-3, page 14.

4. If using control chamber, push bypass valve to relieving position.

5. Unscrew drilling machine from control valve or control chamber

6. Advance boring bar.

7. Remove drill holder and shut-off tool.

### J. INSERT COMPLETION PLUG - See NOTE on page 15

1. Assemble NO-BLO plug inserting tool to the right hand threads in the end of the boring bar of the drilling machine.

2. Attach the completion plug to the plug inserting tool. Lubricate the tool threads and be sure they thread together freely. Check to be sure threads on completion plug

# NO-BLO E-5 OR FH-5 DRILLING MACHINE

and fittings are clean. Apply non-hardening pipe thread sealant to the completion plug threads. FIGURE 42.



**3.** Retract boring bar to its rearmost position.

**4.** Attach drilling machine to valve or control chamber. In next steps, machine will be under pressure - control upward movement of E-5 Machine boring bar - keep face and body clear of upper end of boring bar and ratchet handle.

**5.** If using a control valve, open it fully.

**6.** If using control chamber:

- Pull bypass valve to the bypassing position (twist to lock).
- Loosen handle screw and open the valve gate fully.

**7.** Advance boring bar until the completion plug contacts the top thread in the fitting. Hold the boring bar down with the feed yoke, if desired.

**8.** Rotate the ratchet handle clockwise until the completion plug is firmly screwed into the fitting.

**9.** Reverse ratchet and turn the ratchet handle counter-clockwise to take up the slack. Hold in this position with one hand and strike the end of the ratchet handle with a sharp blow counter-clockwise with the other hand. FIGURE 43.



**10.** Rotate the boring bar counter-clockwise until the inserting tool is free from the completion plug.

**11.** If using a control chamber, push the by-pass valve to the relieving position. If there is full flow from the by-pass valve at this point, rotate the ratchet handle clockwise and seat the completion plug more tightly.

**12.** Remove drilling machine and control valve or control chamber.

**13.** Tighten completion plug with completion plug wrench.

**14.** Apply non-hardening pipe thread sealant to completion cap threads and screw cap tightly on fitting. FIGURE 44.



**15.** Test the entire fitting with soapsuds (add glycerin in freezing weather) or a leak detection fluid.

## **NOTE: TO USE A NO-BLO DEFERRED COMPLETION STOPPER**

A Deferred Completion Stopper provides a stop-off in the NO-BLO Service Line Stopper Fitting (or threaded inlet NO-BLO Service Tee) and also screws into the top of the fitting. This permits the drilling machine and the valve or control chamber to be removed while maintaining a stop-off in the line.

The Deferred Completion Stopper may be installed by following these instructions using E-Z Release type inserting tool and machine adapter nipple or machine body extension listed for use with Deferred Completion Stopper. Lubricate the rubber with Mueller Rubber Stopper Lubricant (Part no. 580657).

The Deferred Completion Stopper may be removed from the fitting by following instruction J, page 8 for removing completion plug from Service Tees.

## **K. TO RE-USE NO-BLO SERVICE LINE STOPPER FITTING**

**1.** Remove completion plug Follow instruction J, page 8 for removing completion plug from NO-BLO Service Tees.

**2.** Refer back to instruction H, page 14 and proceed with the use of the fitting.

# NO-BLO E-5 OR EH-5 DRILLING MACHINE

These instructions are for doing the following NO-BLO operations using the E-5 Drilling Machine or the EH-5 Drilling Machine\*. Also see Operating Instructions for the Mueller E-5 and EH-5 Drilling Machines.

ITEM	SIZES	NO-BLO OPERATIONS
Save-A-Valve Drilling Nipples	¾", 1", 1 ¼", 1 ½" 2"	Drill the Pipe Insert Plug Extract Plug

The following table, at the bottom of page, lists the maximum working pressure and temperature rating of the machine and its equipment. The line pressure must not exceed the amounts indicated while drilling the main, inserting the completion plug or extracting the completion plug.

\*The EH-5 Drilling Machine is a high pressure machine, having a balanced pressure design. The line pressure is equalized within the machine, permitting the boring bar and tool to be easily advanced or easily retracted. It is never necessary to operate this machine against the full effective force of the line pressure. The EH-5 Drilling Machine uses E-5 Drilling Machine tools and equipment.

## A. SELECT THE NO BLO EQUIPMENT REQUIRED

1. Determine the catalog number of the control valve to be used according to the working pressure and temperature of the line to which the nipple is to be attached. See the table below and FIGURE 1.

2. Select the proper E-5 Machine tools and equipment according to the following at top of next column:

CATALOG NO. OF DRILLING MACHINE	TYPE OF VALVE TO BE USED	MAXIMUM WORKING PRESSURE	MAXIMUM TEMPERATURE RATING
E-5	H-10914 H-10918**	125 psig at 100° F 500 psig at 100° F	250° F at 100 psig 250° F at 375 psig
EH-5	H-10914 H-10918**	125 psig at 100° F 1200 psig at 100° F	250° F at 100 psig 250° F at 1140 psig

- a) Size and catalog number of the NO-BLO Save-A-Valve Drilling Nipple to be installed.
- b) Catalog number of the control valve to be used. The required tools and equipment are listed in the Gas Distribution Products Catalog along with the cataloging of the Save-A-Valve Drilling Nipples.

3. Select the drilling tools to be used. The maximum size of the drilling tools which can be used is listed in the Gas Distribution Products Catalog, with the nipple information. Select the proper size of control valve. This is listed in the Catalog with the nipple information.

## B. ATTACH THE NO-BLO NIPPLE TO THE PIPE

1. Thoroughly clean the surface to which the nipple is to be attached.

2. Remove completion cap and completion plug. FIGURE 45.



3. Nipples having welding or threaded inlets:

- a) Nipples having welding inlet - place nipple in desired location and weld pipe line, FIGURE 46.



- b) Nipples having threaded inlet - attach Service Clamp at the desired position. Apply non-hardening pipe thread sealant to the inlet threads of the nipple and screw it into the body of the Service Clamp tightly. FIGURE 47.



**NOTE:** When using a NO-BLO Save-A-Valve Drilling Nipple, having a threaded inlet may be necessary to reduce the working pressure and temperature to that of the clamp or fitting to which the nipple is attached.

## C. TEST THE INSTALLATION

1. Screw test cap on nipple.

2. Apply air pressure and test for leaks with soapsuds (add glycerin in freezing weather) or a leak detection fluid. FIGURE 48.



# NO-BLO E-5 OR EH-5 DRILLING MACHINE

Installing NO-BLO Save-A-Valve Drilling Nipples



48.

3. Remove cap.

4. If installing 1", 1 1/4" or 1 1/2" NO-BLO Nipple, the following additional equipment may be used if desired: H-17615 Center Locating Punch to mark the pipe to aid in starting the drill. See instruction B-5, page 4.

## D. ATTACH DRILLING MACHINE

1. Attach control valve to top of nipple. (If installing 3/4" or 1" nipple, first attach proper bushing to top of nipple and then attach control valve to bushing.)

2. Open control valve fully.

3. Attach machine adapter nipple to the body of the machine. Be sure the gasket is in good condition and in place.

4. Assemble proper size drill and drill holder (or combined drill and holder) to the boring bar of the machine.

5. Coat drill thoroughly with Mueller Cutting Grease. FIGURE 49.



49.

6. Retract boring bar to its rearmost position.

7. Place drilling machine on control valve and tighten machine adapter nipple into control valve. FIGURE 50.



50.

## E. DRILL THE MAIN

1. Slowly advance boring bar until point of drill contacts the pipe. Then retract boring bar a slight amount.

2. Adjust feed tube and yoke so that the yoke engages the collar on boring bar. Tighten locking mechanism against underside of collar.

3. Drill the hole by operating the ratchet handle clockwise and turning the feed tube and yoke clockwise, little at a time, FIGURE 51.



51.

Use a light, even feed at the start, then a heavier feed, and finish with a light, even feed. To prevent over-

feeding when drilling small holes and also when starting to drill larger holes, apply the feed by gripping the knurled section of the feed tube instead of the feed handles. E-5 and EH-5 Machines are furnished with a combination ratchet and crank handle. When drilling small holes, the crank handle should be turned upward and rotated clockwise in continuous circles instead of ratcheting.

4. Continue drilling until a hole is drilled in the pipe. This can be determined by the feel of the feeding mechanism and the pull of the ratchet handle.

## F. REMOVE THE DRILLING MACHINE

1. When the drilling operation is completed, retract the boring bar to its rearmost position. Be sure the point of the drill is above the valve gate.

**⚠ CAUTION: DO NOT REVERSE THE ROTATION OF THE RATCHET HANDLE WHEN RETRACTING THE BORING BAR - PRESSURE INSIDE THE MACHINE WILL TEND TO RAISE THE BORING BAR FORCEFULLY - KEEP FACE AND BODY CLEAR OF UPPER END OF BORING BAR AND RATCHET HANDLE. USE THE FEED YOKE TO CONTROL THE UPWARD MOTION OF THE BORING BAR THEREBY PREVENTING SHOCK OR DAMAGE TO THE DRILLING MACHINE, OR BODILY INJURY.**

2. Close control valve. (Open bleeder Valve on EH-5).

3. Remove drilling machine and machine adapter nipple as a unit.

4. Advance boring bar.

5. Remove drilling tools.

6. Attach required piping to valve.

7. Open control valve when ready for flow through the NO-BLO Save-A-Valve Drilling Nipple connection.

## G. INSERT COMPLETION PLUG AND REMOVE VALVE

1. When flow through Save-A-Valve Drilling Nipple connection is no longer required, close the control valve.
2. Remove piping from control valve.
3. Assemble plug inserting tool to the right hand threads in the end of the boring bar of the drilling machine.
4. Attach the completion plug to the plug inserting tool. Lubricate the tool threads and be sure they thread together freely. Check to be sure threads on completion plug and fittings are clean. Apply non-hardening pipe thread sealant to the completion plug threads. FIGURE 52.



5. Retract boring bar to its rearmost position.
6. Attach drilling machine to control valve. (Close bleeder valve on EH-5 Machine.) In next steps, machine will be under pressure - control upward movement of E-5 Machine boring bar - keep face and body clear of upper end of boring bar and ratchet handle.
7. Open control valve fully.
8. Advance boring bar until the completion plug contacts the top thread in the nipple. Hold the boring down with the feed yoke, if desired.
9. Rotate the ratchet handle clockwise until the completion plug is firmly screwed into the nipple.
10. Reverse ratchet and turn the ratchet handle counter-clockwise to take up the slack. Hold in this position with one hand and strike the end of the ratchet handle with a sharp blow counter-clockwise with the other hand. FIGURE 53.



11. Rotate the boring bar counter-clockwise until the inserting tool is free from the completion plug.
12. If using EH-5 Machine, open bleeder valve. If there is full flow from the bleeder valve at this point, close it and rotate the ratchet handle clockwise and seat the completion plug more tightly.
13. Remove drilling machine and control valve.
14. Tighten completion plug with completion plug wrench.
15. Apply non-hardening pipe thread sealant to completion cap threads and screw cap tightly on nipple. FIGURE 54.



16. Test the entire nipple with soapsuds (add glycerin in freezing weather) or a leak detection fluid.

## H. TO RE-USE NO-BLO Save-A-Valve DRILLING NIPPLE

1. Remove completion plug. Follow instruction J, page 8 for removing completion plug from NO-BLO Service Tees.
2. Attach required piping to control valve.
3. Open control valve when ready for flow through the Save A-Valve Drilling Nipple connection.



**MUELLER® | ECHOLOGICS® | HYDRO GATE® | HYDRO-GUARD® | HYMAX® | i20® | JONES® | KRAUSZ® | MI.NET® | MILLIKEN® | PRATT® | SINGER® | U.S. PIPE VALVE & HYDRANT**

---

1.800.423.1323 - [www.hydrogate.com](http://www.hydrogate.com) - [moreinfo@hydrogate.com](mailto:moreinfo@hydrogate.com)

**INTERNATIONAL** - 1.423.490.9555 - [www.mueller-international.com](http://www.mueller-international.com) - [international@muellercompany.com](mailto:international@muellercompany.com)

Mueller refers to one or more of Mueller Water Products, Inc. (MWP), a Delaware corporation, and its subsidiaries. MWP and each of its subsidiaries are legally separate and independent entities when providing products and services. MWP does not provide products or services to third parties. MWP and each of its subsidiaries are liable only for their own acts and omissions and not those of each other. Mueller brands include Mueller®, Echologics®, Hydro Gate®, Hydro-Guard®, HYMAX®, i20®, Jones®, Krausz®, Mi.Net®, Milliken®, Pratt®, Pratt Industrial®, Singer®, and U.S. Pipe Valve & Hydrant. Please see [muellerwp.com/brands](http://muellerwp.com/brands) to learn more.



Copyright © 2021 Mueller Water Products, Inc. All Rights Reserved. The trademarks, logos and service marks displayed in this document are the property of Mueller Water Products, Inc., its affiliates or other third parties. Products marked with a section symbol (§) are subject to patents or patent applications. For details, visit [www.mwppat.com](http://www.mwppat.com). These products are intended for use in potable water applications. Please contact your Mueller Sales or Customer Service Representative concerning any other application(s).